



SOFTWARE OPERATING GUIDE

FUTURA ONE
FUTURA *PRO* ONE

FUTURA ONE ABUS®
FUTURA *PRO* ONE ABUS®



vers. 7

Edition: October 2018

(c) 2017 SILCA S.p.A. - Vittorio Veneto

The Manufacturer declines any responsibility for possible inaccuracies in this document due to printing or transcription errors. The Manufacturer reserves the rights to alter the information without prior notice, except when they affect safety. This document or any of its parts cannot be copied, altered or reproduced without written authorization from the Manufacturer. Keep the manual and look after it for the entire life cycle of the machine. The information has been drawn up by the manufacturer in his own language (Italian) to provide users with the necessary indications to use the key-cutting machine independently, economically and safely.

IMPORTANT NOTE: in compliance with current regulations relating to industrial property, we hereby state that the trade-marks or trade names mentioned in our documentation are the exclusive property of authorized manufacturers of locks and users. Said trade-marks or trade names are nominated only for the purposes of information so that any lock for which our keys are made can be rapidly identified.

INDEX

1	SEARCHES	9
1.1	VEHICLE keys.....	9
1.2	DIMPLE / TRACK keys.....	9
1.3	FULL KEY SEARCHING.....	9
1.4	TRASPONDER GUIDE	9
1.5	DATA CARD/SERIE info	13
1.6	Using a CUTTING DATA CARD	15
1.7	Cutting DIMPLE/TRACK/TUBULAR keys and CUTTING SPEED	21
2	COPY VEHICLES KEYS.....	22
3	FAVORITE'S.....	25
4	QUEUE OF JOBS	26
4.1	"STANDARD" QUEUE OF JOBS.....	26
4.2	"OEM" QUEUE OF JOBS (only with OEM CLIENT function enabled)	27
4.2.1	OEM CLIENT function activation	27
4.3	"SSI" QUEUE OF JOBS	29
5	ENGRAVING.....	33
6	OPTIONS	43
6.1	INFO	43
6.2	CALIBRATION	44
6.2.1	DIMPLE/TRACK keys clamp calibration.....	44
6.2.2	MOBILE TRACER 01T calibration	46
6.2.3	DIMPLE/TRACK keys Adapters calibration	46
6.3	SETTINGS.....	47
6.3.1	Zero-point Calibration (DIMPLE/TRACK key).....	47
6.3.2	Options.....	49
6.3.2.a	General.....	49
6.3.2.b	Preferences DIMPLE/TRACK key.....	51
6.3.3	USE	52
6.3.3.a	ACCESS POINT mode (Wi-Fi connection between machine and Tablet).....	52
6.3.3.b	ETHERNET with connection to LAN and router.....	54
6.3.3.c	TETHERING USB mode	55
6.3.3.d	LOCAL NETWORK mode	57
6.3.4	IMPORT HOOKS POSITION FILE	61
6.4	MACHINE MAINTENANCE	63
7	MACHINE UPDATE and REGISTRATION.....	66
7.1	MACHINE REGISTRATION	66
7.2	MACHINE SOFTWARE UPDATE	72
7.2.1	Update by TABLET	72
7.2.2	Update by USB PEN.....	74
7.2.3	Update with LOCAL NETWORK connected to the internet	75
7.2.4	Update with SRS Program (Silca Remote Service)	77
7.3	APP UPDATE (Silca.apk e SilcaKeyboard.apk)	79
8	BACKUP / RECOVERY	81
9	USER SERIES	82
10	CODE MAKER	86
11	TRASPONDER GUIDE	87
12	CHANGING TABLETS	89
13	FUTURA PROCEDURE TO CLEAR CACHE	91

• **PROGRAM START**



To start the program tap the icon on the tablet screen.

If the program does not start check the network settings/use (see Ch.6.3.3).

FUTURA PRO ONE

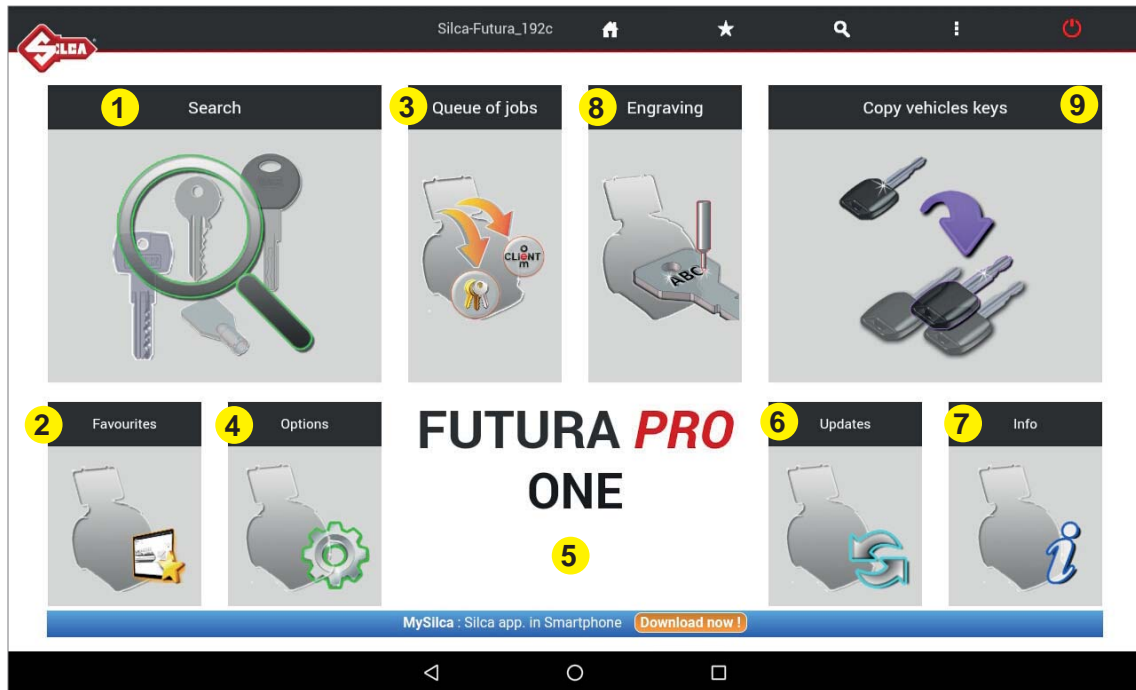

1- Search

Menu used to select a category of Series Searches.

2 - Favourites

Menu used to access a series of searches previously set up as favourites.

3 - Queue of jobs

Menu used to run the job queue previously created by the search menu or optional OEM Client menu (optional - Ch.4.2).

4 - Options

Menu used to set up the machine.

5

The name of the machine model being used is shown.

6 - Upgrades

Menu used to update machine software.

7 - Info

Menu showing machine details.

8 - Engraving

Menu used to engrave keys (head or neck) and medals (Ch.5).

9 - Copy vehicles keys

This function is used to copy vehicle keys with laser track cuts, by means of facilitated searching.

FUTURA ONE

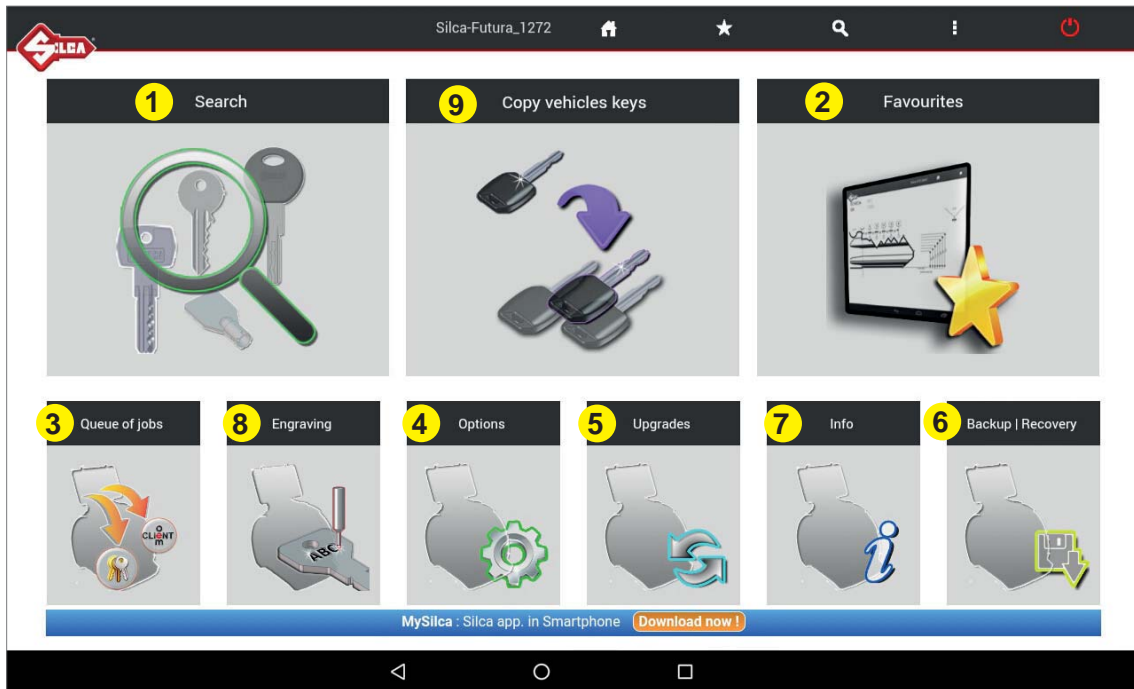

1- Search

Menu used to select a category of Series Searches.

2 - Favourites

Menu used to access a series of searches previously set up as favourites.

3 - Queue of jobs

Menu used to run the job queue previously created by the search menu or optional OEM Client menu (optional - Ch.4.2).

4 - Options

Menu used to set up the machine.

5 - Upgrades

Menu used to update machine software.

6 - Backup | Recovery

Menu used to save machine data and restore them when necessary.

7 - Info

Menu showing machine details.

8 - Engraving

Menu used to engrave keys (head or neck) and medals (Ch.5).

9 - Copy vehicles keys

This function is used to copy vehicle keys with laser track cuts, by means of facilitated searching.

Silca-Futura_bb03

- Silca-Futura_bbe3** Machine ID: shows the name of the Futura machine.
- Initial menu:** tap the symbol to go back to the initial menu.
- Favourites:** tap the symbol to view the data cards/series saved in the favorites menu.
- Search menu:** tap the symbol for direct access to the “Search” menu.
- Information:** tap the symbol to view information about the Futura machine
- Turn off machine:** tap the symbol to turn off the Futura machine without affecting the software; wait until the green light goes out and then turn off the machine with the ON/Emergency push button.

• **CHOICE OF KEYBOARD**

When the FUTURA program is started you are required to choose the type of keyboard you will use for entering data.

SILCA Keyboard: smaller keyboard specially designed for the Futura program.

Google Keyboard: standard Android tablet keyboard.

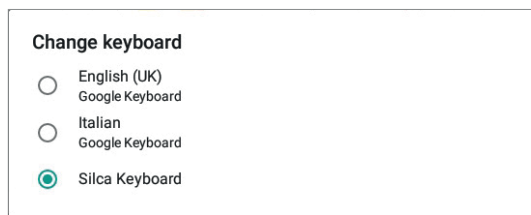

If you have chosen the Silca keyboard you can go back to Android by hitting the key on the Silca keyboard.



• **CHANGE PROGRAM LANGUAGE**

The default program language is English. To change language go to the **Options** menu (Ch.2), select **Settings -> Options -> General -> Language** and choose the language you require.

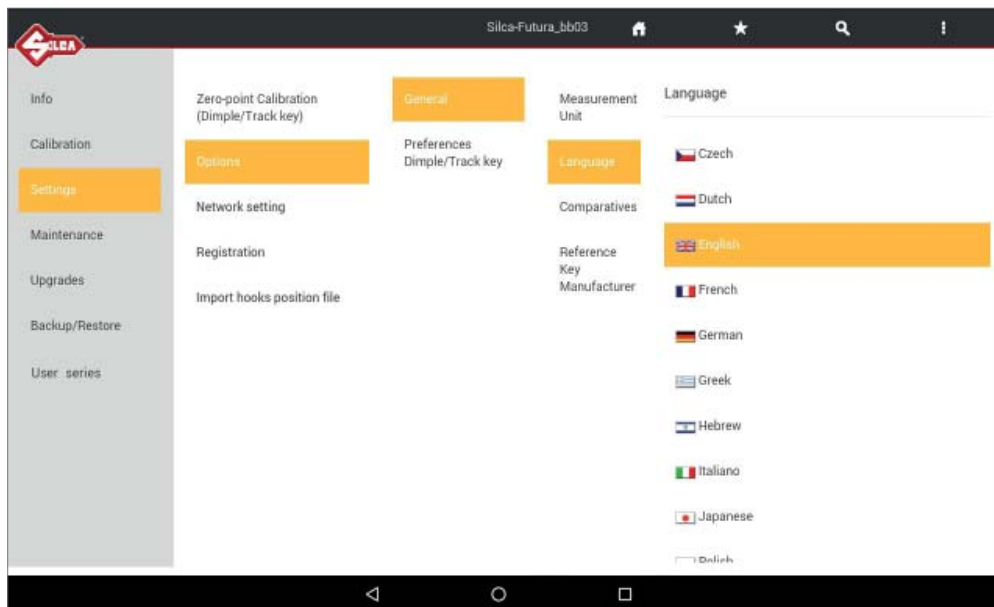

• **MEASURING UNITS**

All the values given in the program for the technical measurements of keys and clamps are expressed in hundredths of a millimetre (default) or thousandths of an inch, according to the measuring unit chosen from the “Options” menu.

- **DROP-DOWN MENU**



To view this menu on the Tablet scroll from left to right to open the list:

Connect to: used to find the Futura One / Futura Pro One machine, if there is a LAN connection or Wi-Fi Access Point.

Reload page: used to reload the page if it is not properly viewed/activated.

Restart Machine: used to restart the machine.

Machine IP address: used to enter the FUTURA IP address manually (default is 192.168.0.1).

Reset Axes: used to clear the axes on the machine.

Machine Status: used to see connection status between the machine and Tablet.

Change Keyboard: used to select and set the type of keyboard to be used (Silca or Google keyboard)

Machine Registration: used to register the machine when the Tablet is connected to a Wi-Fi network with internet access.

Update FUTURA: used to download new updates for the machine when the Tablet is connected to a Wi-Fi network with internet access:

- by tablet connected to a Wi-Fi network with access to the internet (Ch.7.2.1).
- by USB PEN DRIVE and PC with access to the internet (Ch.7.2.2).

Recovery tools: this function is protected by a password and is for the exclusive use of Silca personnel.

In addition, the Silca App version installed on the Tablet is shown below.

1 SEARCHES

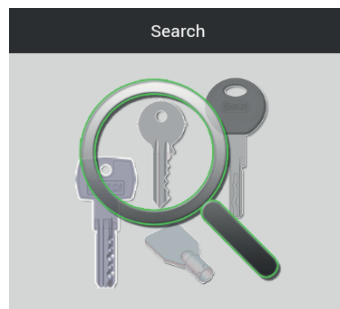

When the Searches menu is opened, the following window appears:

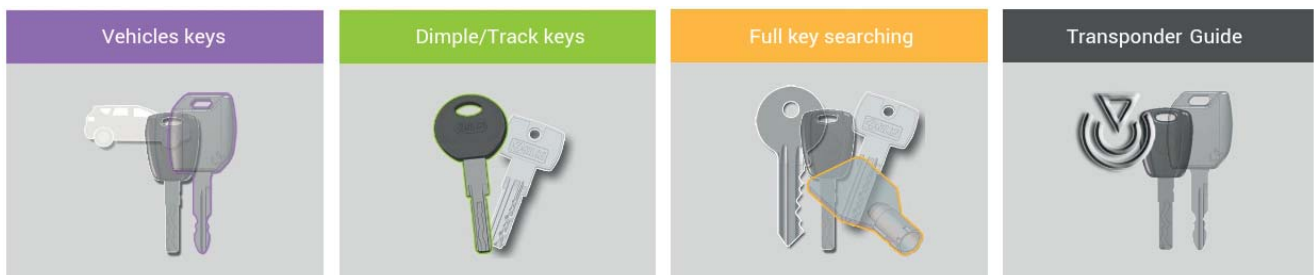

1.1 VEHICLE keys

This menu is used to restrict a search to the category of standard edge cut and track vehicle keys only (e.g.: HON66GP - HU66P - SIP22LP - TOY40P ...)

1.2 DIMPLE / TRACK keys

This menu is used to restrict a search to the dimple/track category of keys (e.g. AB48 - AB62 - AB84 - CS62 - IE15 ...).

1.3 FULL KEY SEARCHING

This menu is used to make extended searches not restricted to categories.

1.4 TRASPONDER GUIDE

The Transponder Guide contains all the transponder key copying solutions provided by Silca (chap.11).

See example of DIMPLE keys search flow.

When you enter the DIMPLE/TRACK keys category the following window appears for you to enter the search parameters.

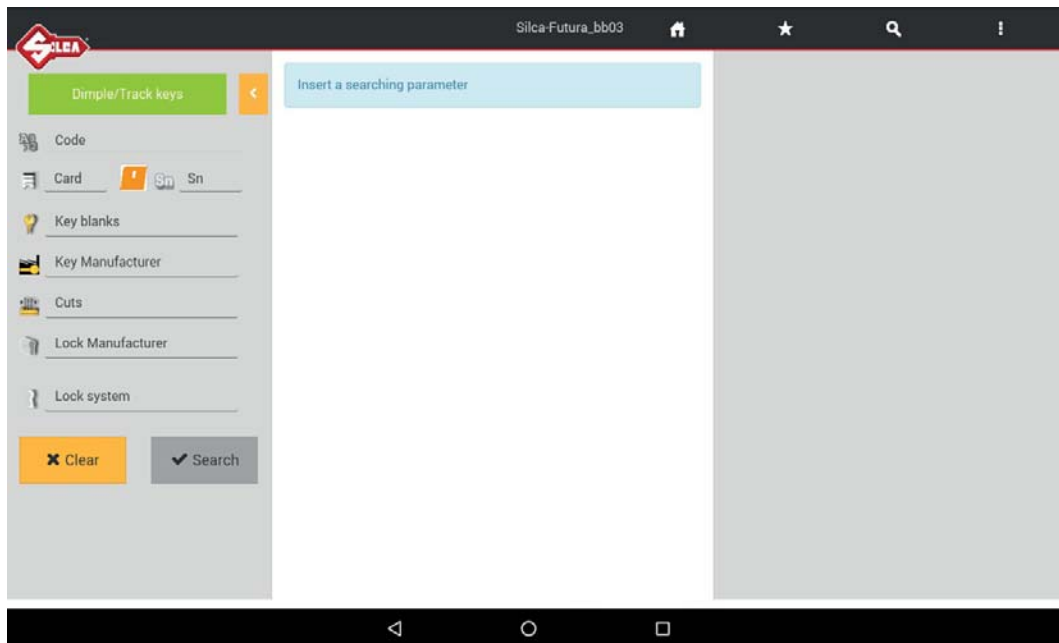
**SEARCH Parameters**

Code: enter the indirect key-cutting code.

Card / Sn: enter the card number or serial number assigned by Silca.



Instacode icon: it's possible to search for a card into Instacode program.

On certain versions the function is already enabled. Where it is not enabled it can be requested as an option.

Key blanks: enter the Silca/Ilco key blank code or comparative.

Key manufacturer: enter name of key manufacturer.

Cuts: enter number of cuts for the key to be included in the search.

Lock Manufacturer: enter the brand of lock to be included in the search.

Lock system: enter the name of the lock system.

Press “**Clear**” to delete the entered fields.

After entering one or more parameters, tap the “**Search**” button to start the search. This operation will show the data relating to the lock systems found and information about the Silca/Ilco key blank, if applicable.

Tap  on the left-hand side of the page to re-open the Search Parameters window.

See example of VEHICLE keys search flow

When you enter the VEHICLE keys category the following window appears for you to enter the search parameters.

Tap “VEHICLE MAKE”; a guided procedure appears to simplify your search.

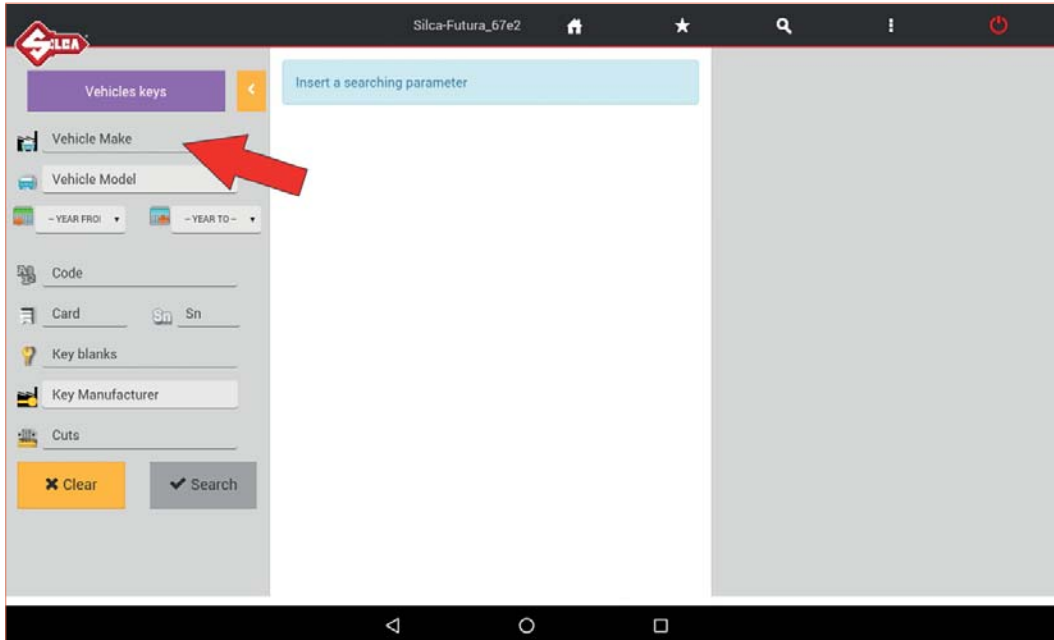

Tap “VEHICLE MAKE”; a guided procedure appears to simplify your search.

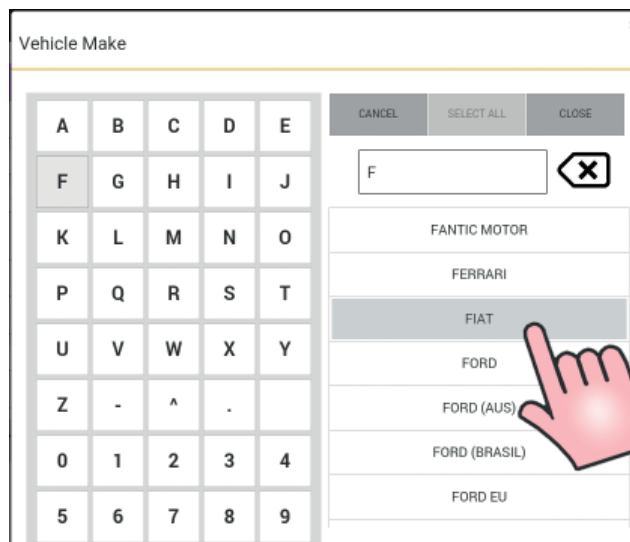

Enter the first letters of the VEHICLE MODEL and select the one you require.

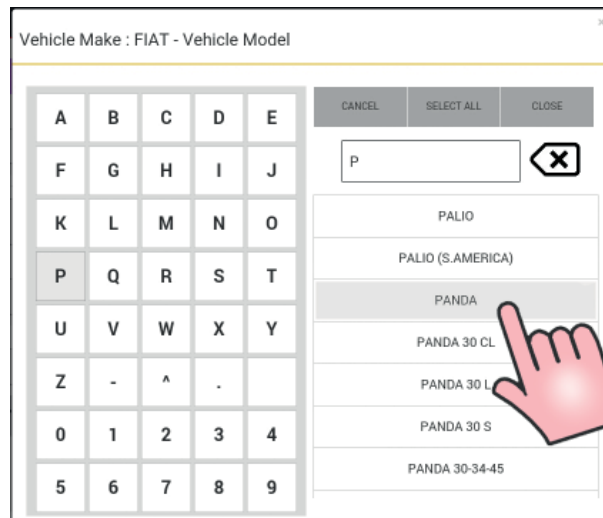

Select the YEAR.

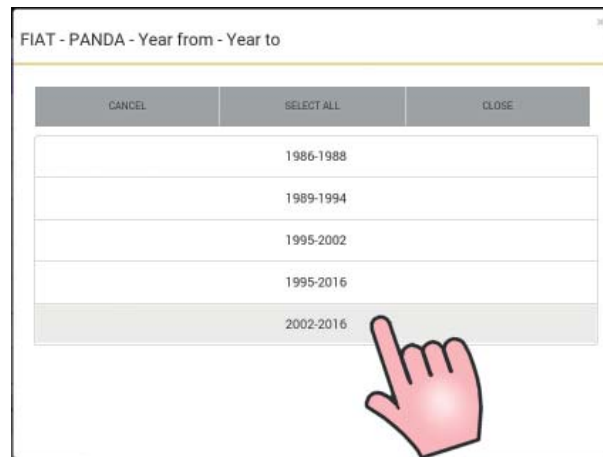

Select the CARD key to access the cutting data card.

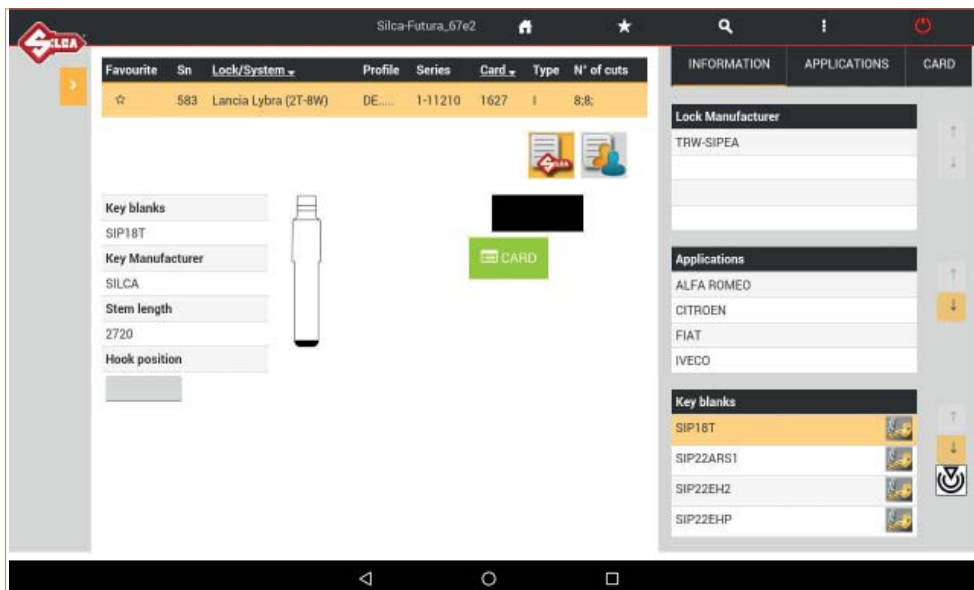

1.5 DATA CARD/SERIE info

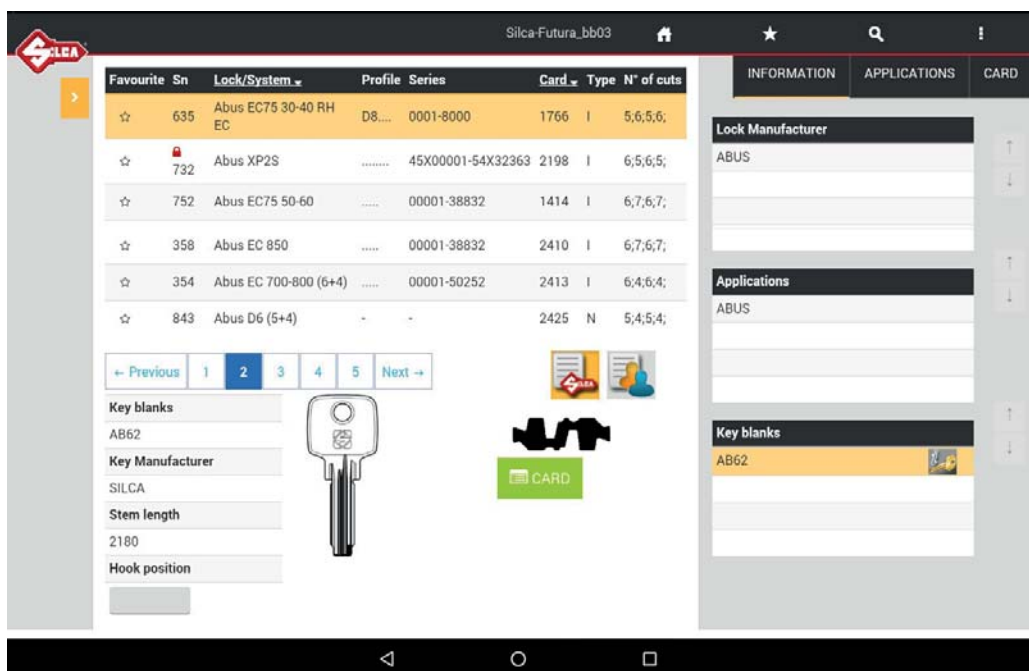

To access the cutting card select the relevant line and tap the “OPEN CUTTING CARD” button.

In the section of the window showing the search results

Favourite	Sn	Lock/System	Profile	Series	Card	Type	N° of cuts
-----------	----	-------------	---------	--------	------	------	------------

- Order searches by tapping the arrow next to the relative fields.
- Select a series from those shown, or search for it on the next pages: < Previous 1 2 3 ... 7 Next >
- Tap this icon to access the “Transponder Guide” (for vehicle keys).
- Select the “Silca” or “User” series:
 - Tap the Silca icon “Silca” is the default icon for viewing Silca series.
 - Tap the User icon tap “User” to view the existing user series (Ch.9) associated to the selected card.
- Tap the special field to enter the Hook position: it is automatically saved when the keyboard is turned off.

There are “3 folders” on the right of the screen:

INFORMATION: shows information about the lock make, applications and Silca/Iloco key blank. Info about a key can be viewed by tapping the field relating to the key blank.

APPLICATIONS: shows the applications for which this key blank is used: locks, cylinders, vehicle model, etc.

INFORMATION	APPLICATIONS	CARD
Cylinders		
ABUS		
EC 75/30		AB62
EC 75/40		AB62

CARD: shows information relating to accessories needed for cutting keys with the Futura One / Futura Pro One key-cutting machine.

INFORMATION	APPLICATIONS	CARD
Clamp		
Part Number		
1 01R		D942570ZR
Right Jaw		
Part Number		
1 02J		D743254ZB

KEY BLANK

To gain access to additional information regarding the Silca key blank simply tap on the following icon



- List of other Silca key blanks that can be used
- List of comparative key blanks
- List of Brand names linked to the Silca key blank.

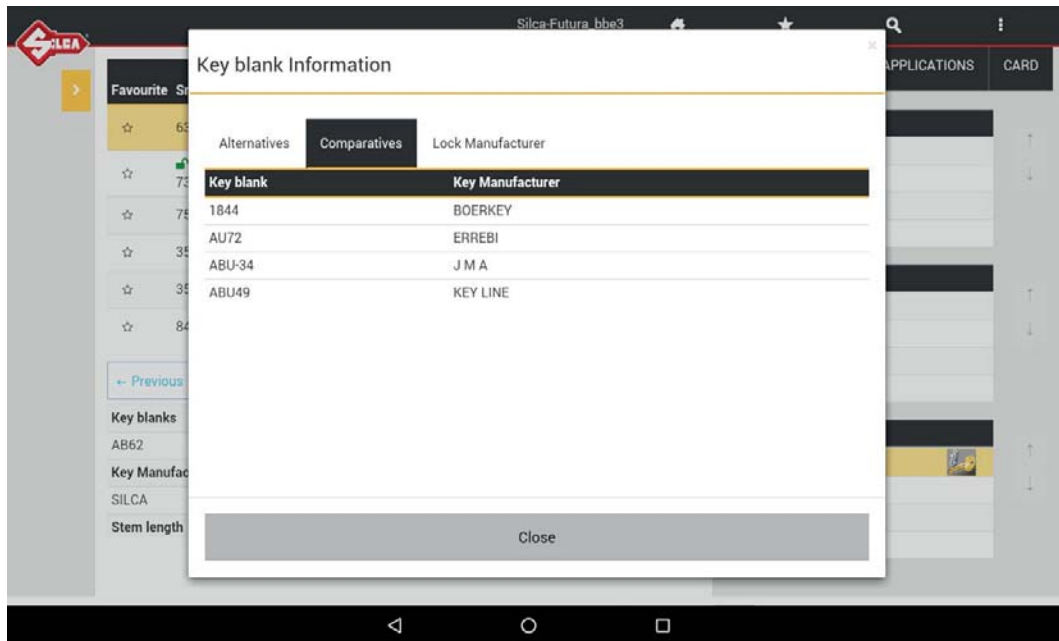

1.6 Using a CUTTING DATA CARD

Example: Data card for DIMPLE keys

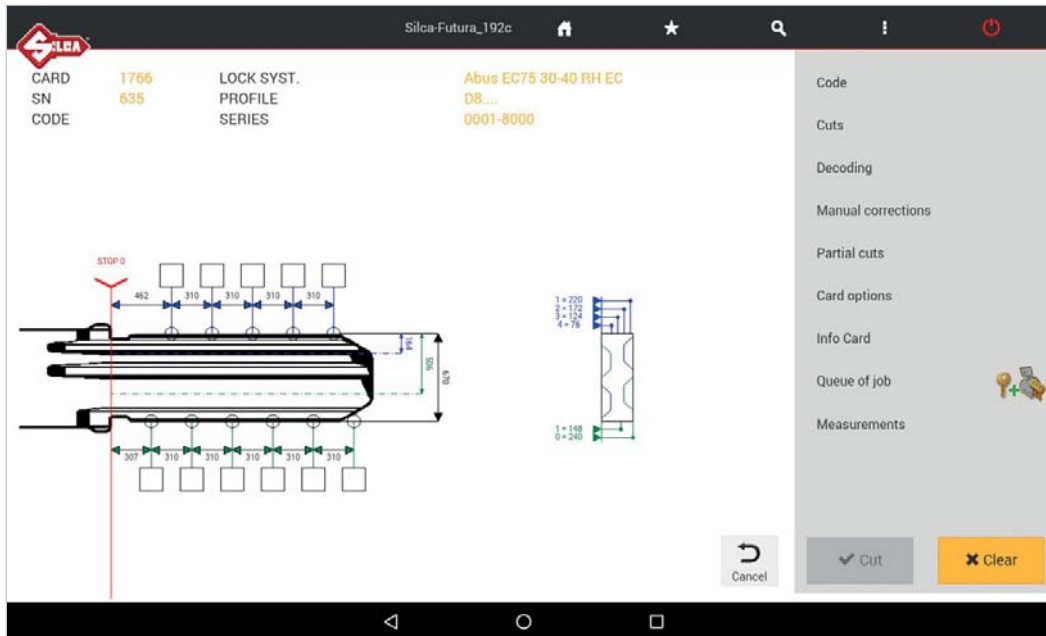

The screen shows all the technical details relating to the selected cutting card (e.g. **Card, SN, Profile, Series, Spaces, Depth**).

Tap the Cancel key to go back to the previous screen.

The list on the right contains the functions listed below:

- **CODE:** enter the indirect code for cutting the key.
- **CUTS:** this function is used to enter direct cuts.

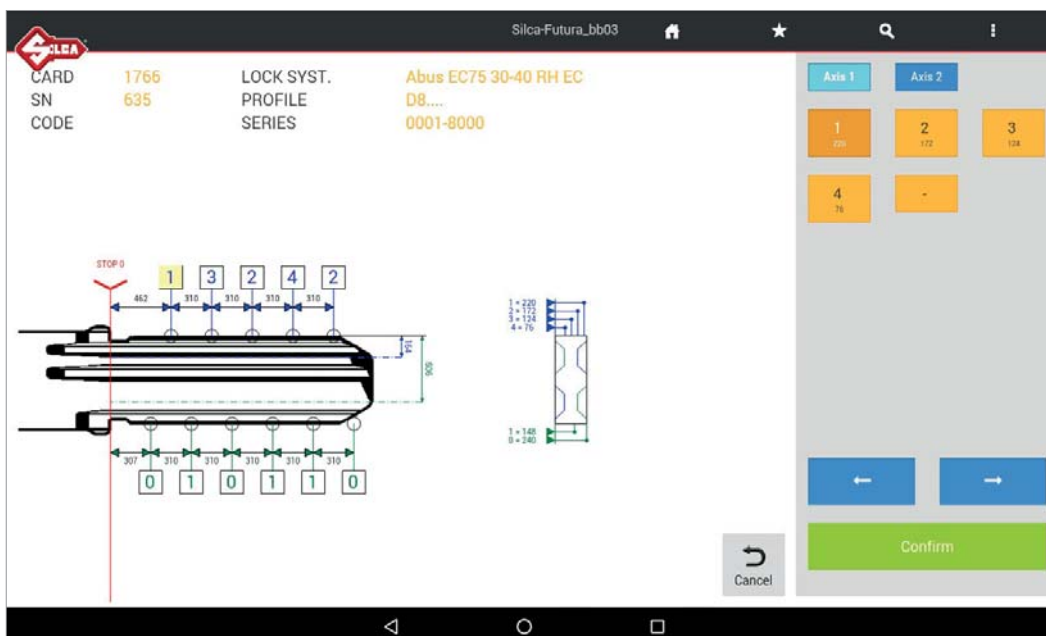

- **QUEUE OF JOBS:** if the cut is filled and correct you can save your job in “Queue of Jobs” by tapping the following icon (the job can then be done afterwards).

Tap on “Queue of Jobs” to display the list of jobs available.

- **DECODING:** used to decode the cuts on the original key.

ATTENTION: make sure the key to be decoded is clean.

ATTENTION: anodised aluminium dimple/laser keys, plastic keys or any other key without electrical conductivity **CANNOT BE** decoded! For these types of keys digit the cuts directly or enter the indirect code if the SSN in use allows it.

Tap “Decoding”: information appears regarding the position of the key in the clamp.

To continue tap START and perform the operations described on the screen.

At the end of the operation tap OK.

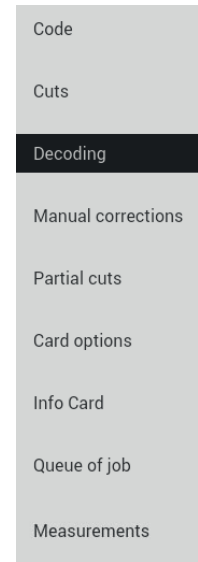
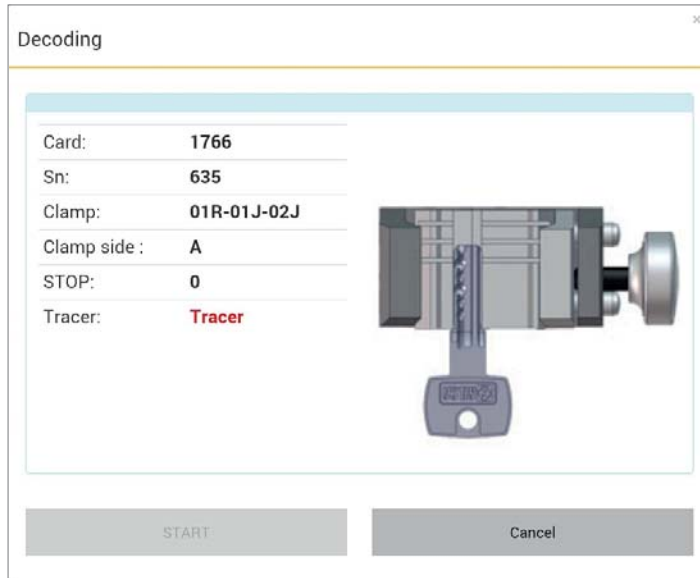

To view the decoded measurements and the measurements read on the key, tap “Decoded Values” on the bottom of the screen.

Decoded data 1766

Axis: 1		Axis: 2		
N.	Symbol	Nominal value	Depth	Offset
1	1	220	221	-1
2	3	124	124	0
3	2	172	172	0
4	1	220	220	0
5	2	172	172	0

Copy key with measurements read

Close

Then tap “CUT” to cut the key using the combination provided by the previous operation.

Copy key with measurements read: after decoding a key the cuts can be verified and compared to the keys original cuts. If the cuts “Offset” values are significant, it’s possible to cut the key by using the measurements just read (not the keys original cuts nominal values that are in the card) by inserting a check “flag” in the appropriate box.

NOTE: when decoding keys, you must use the clamp designated by the software as well as the stop position designated in order to decode the key properly. Use of other clamp or stop positions will result in a misread key. Once decoded, should you receive the message “key blank not allowed” or “bad permutation”, the key may not have been positioned properly. As a result the software will not recognize the key blank or the depths read will not correspond with any of the codes in the code series database. If you are sure that the proper card and key blank were used, reposition your key and try again.

- **MANUAL CORRECTIONS:** to enter manual adjustments in the relative fields for X axis and Y axis, activate the “Use corrections” flag”, tap “Save” and then “Close”.

Adjustments: from -30 to +30 hundredths of mm (+/- 118 thousandths of an inch)

An icon  indicates when the manual adjustment is active.

- Code
- Cuts
- Decoding
- Manual corrections**
- Partial cuts
- Card options
- Info Card
- Queue of job
- Measurements

Confirm with “Save”.

- **PARTIAL CUTS:** used to make a search for correspondence with the code table (if applicable): enter the known cuts and tap “Search”.

Partial Cuts

Symbols

Axis	Permutation
1	5 2 3

Code	Quantity	Axis 1
BC782	1	5; 2; 3; 1; 1
BC783	1	5; 2; 3; 1; 2
BC784	1	5; 2; 3; 1; 3
BC785	1	5; 2; 3; 1; 4

- Code
- Cuts
- Decoding
- Manual corrections
- Partial cuts**
- Card options
- Info Card
- Queue of job
- Measurements

Cutting tree: function accessible only from “Partial cuts” and enabled only for Data cards/Series with code tables available. Tap the “Cutting Tree” key to continue.

Cutting Tree

N° key blanks required: **4**
 Codes selected: **Key n° 1**

Code	Cuts
Key n° 1	
BC782	52311
BC783	52312
BC784	52313
BC785	52314
BC789	52324
BC790	52325
BC795	52335
BC796	52336
BC802	52346
BC803	52347
BC853	52357
BC858	52367
Key n° 2	
BC786	52321

- The list of keys shown in the cutting tree coincides with the list of keys shown in the “Partial cuts” window; however, here the keys are listed according to Groups, Code and Cuts in order to reduce to a minimum the number of key blanks to be used.
- The box at the top of the screen shows the maximum number of key blanks to be used for all the possible cut combinations listed.
- Each Group needs a new key blank to cover all the cut combinations it lists (work down from top). Select the group and/or single code and tap the QUEUE key to place them in the job queue.
- Tap Close, OK, and then Queue of Job.
- The jobs must be carried out in progressive order, starting from the key with the shallowest cuts to those with deeper cuts.

• **CARD OPTIONS**

- Code
- Cuts
- Decoding
- Manual corrections
- Partial cuts
- Card options**
- Info Card
- Queue of job
- Measurements

Depth removal step (for DIMPLE keys only): this value indicates the amount of material trimmed by the cutter at each passage (example expressed in hundredths of a millimeter).

- **INFO CARD:** views information about the clamp to be used, the jaws, the key stop, the tracer, the cutter and key blank.

Tap the relevant icons to see images and part code.

- Code
- Cuts
- Decoding
- Manual corrections
- Partial cuts
- Card options
- Info Card**
- Queue of job
- Measurements

- **[Note]:** tap “Note” (when shown) to view data card notes, i.e. further specific information relating to the position of the key or an accessory, etc.

- **MEASUREMENTS:** view information regarding the measurements of SPACES and DEPTH on the card.

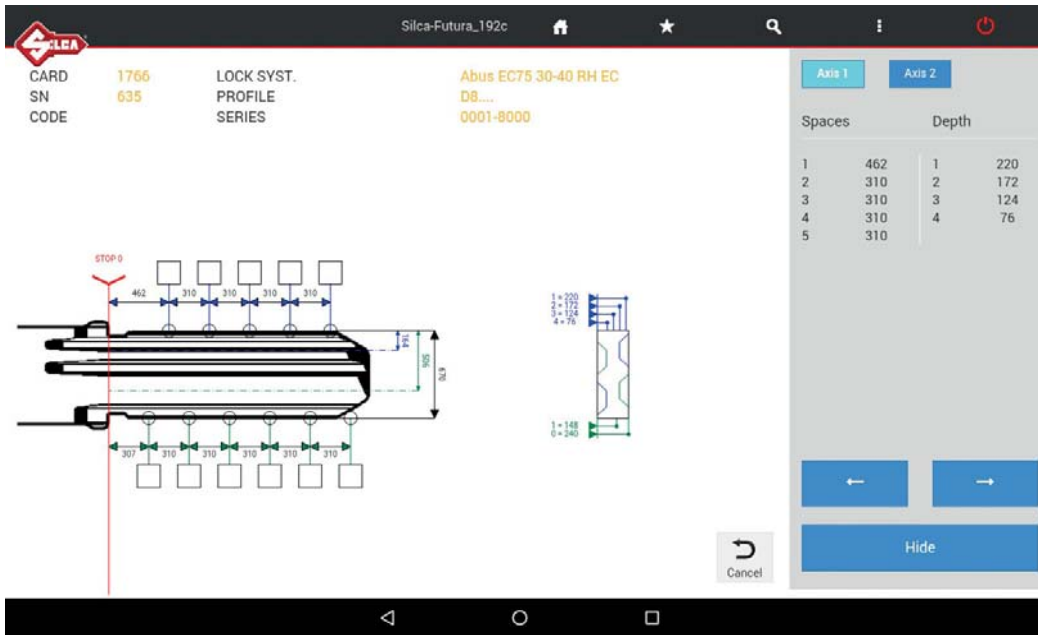

- Code
- Cuts
- Decoding
- Manual corrections
- Partial cuts
- Card options
- Info Card
- Queue of job
- Measurements**

1.7 Cutting DIMPLE/TRACK/TUBULAR keys and CUTTING SPEED

To make a cut on the key, tap CUT : information is shown about the position of the key in the clamp.

1) For DIMPLE keys

Cutting speed change (relates to carriage advancement).

NOTE: the default value set by Silca is 100.

To change the Silca settings, tap the required value:

- With a value of 110 (the carriages will advance at a speed 10% higher than the default setting).
- With a value of 90 or 80 (the carriages will advance 10% or 20% more slowly than the default setting).

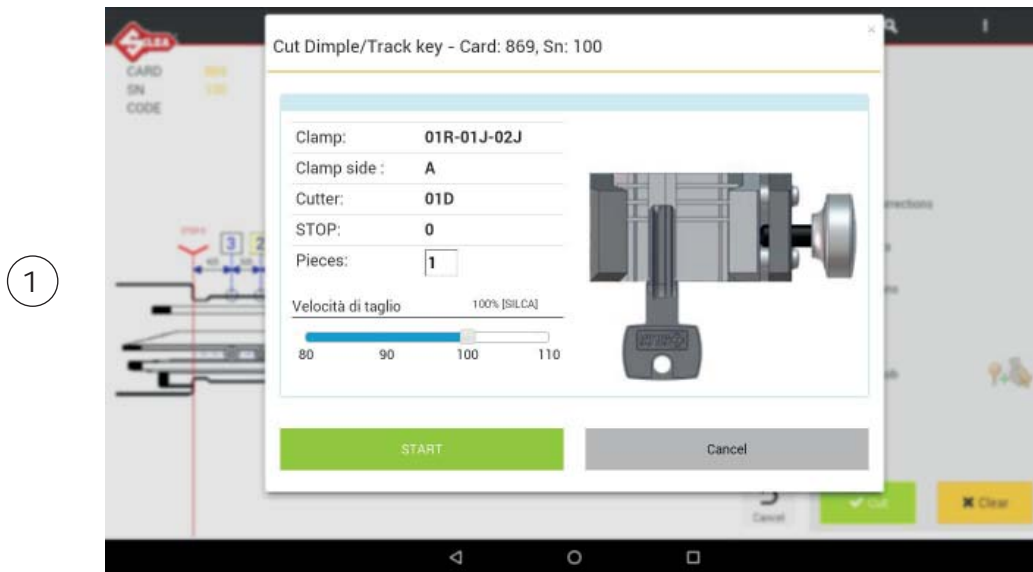

2) For TRACK keys

Steps: used to edit the default number of passes during key cutting. The value is memorised once it has been edited.

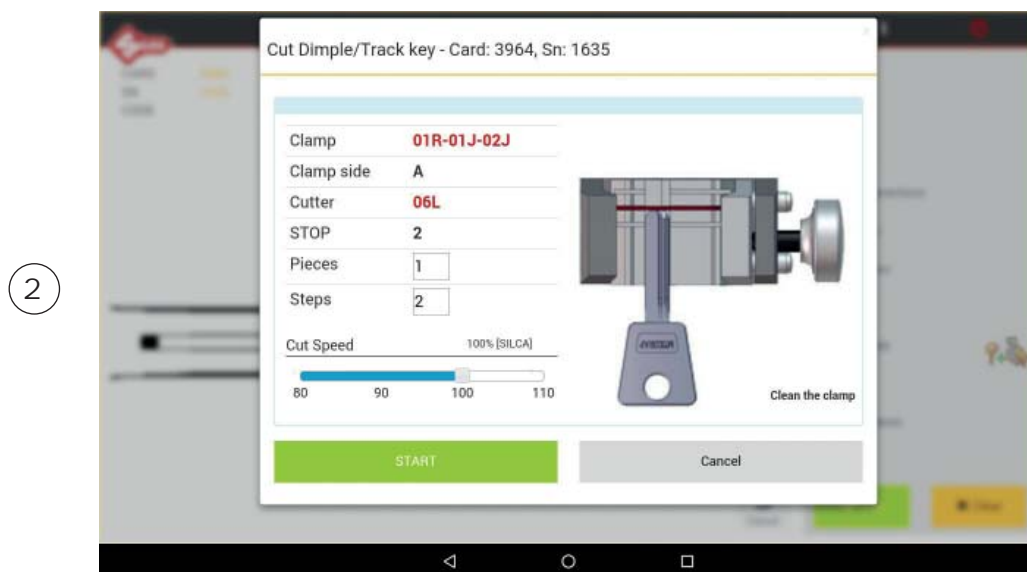

The following can be set:

Pieces: indicates how many keys you wish to cut.

Press START to begin the procedure.

2 COPY VEHICLES KEYS



This function is used to copy vehicle keys with laser track cuts, by means of facilitated searching.

Searches are made by MAKE -> MODEL -> YEAR

In that order:

- after confirming the “Make”, the “Model” field activates;
- after confirming the “Model”, the “Year” field activates.

The search has a filter to speed up results (digit the initial letter of the make or model).

When a field is highlighted in green it means at least one of the keys included has an associated hook position (see Ch.6.3.4).

Example: FIAT -> 500 -> 2007

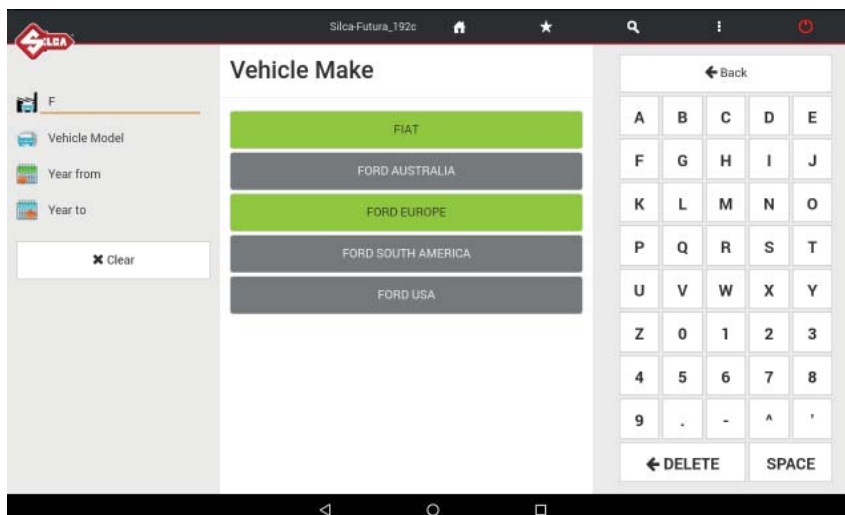
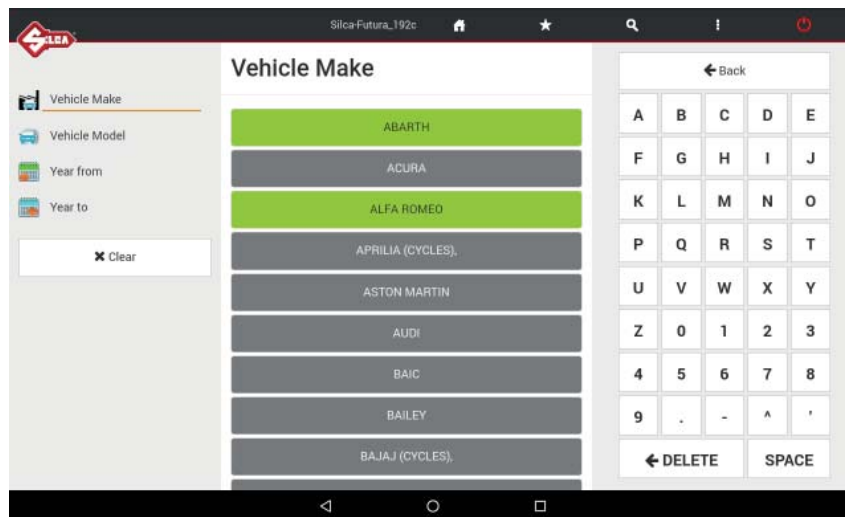

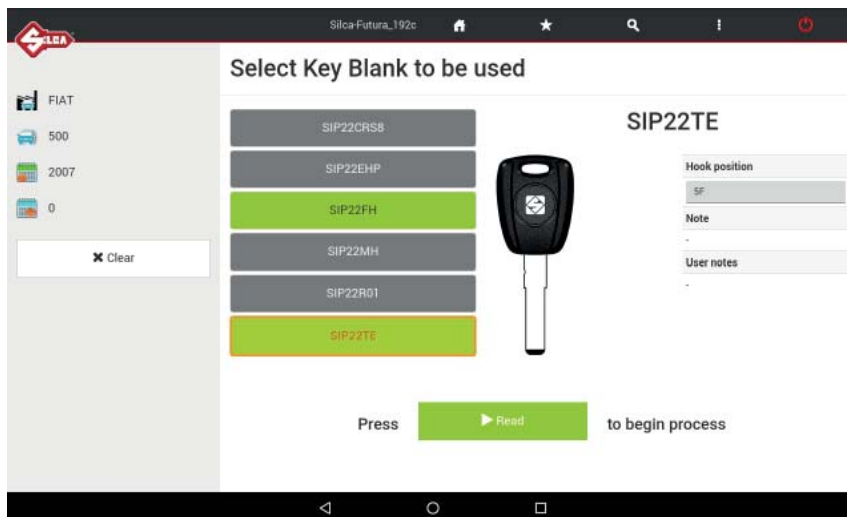
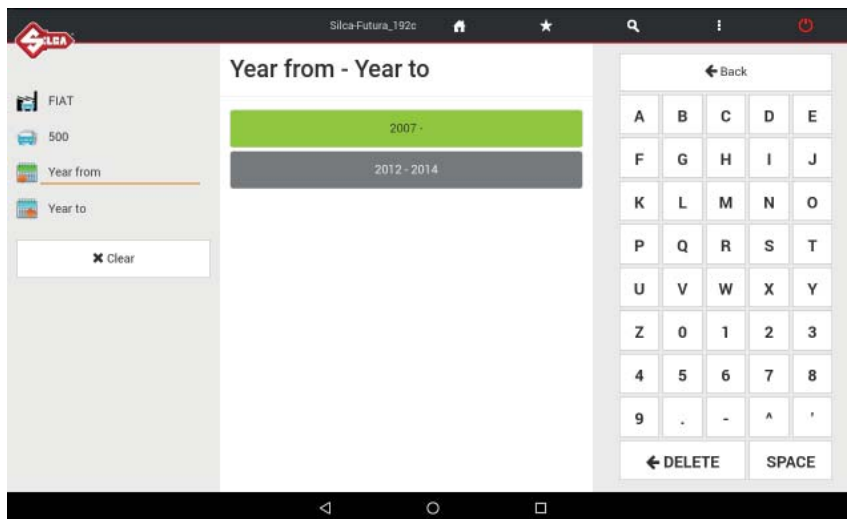
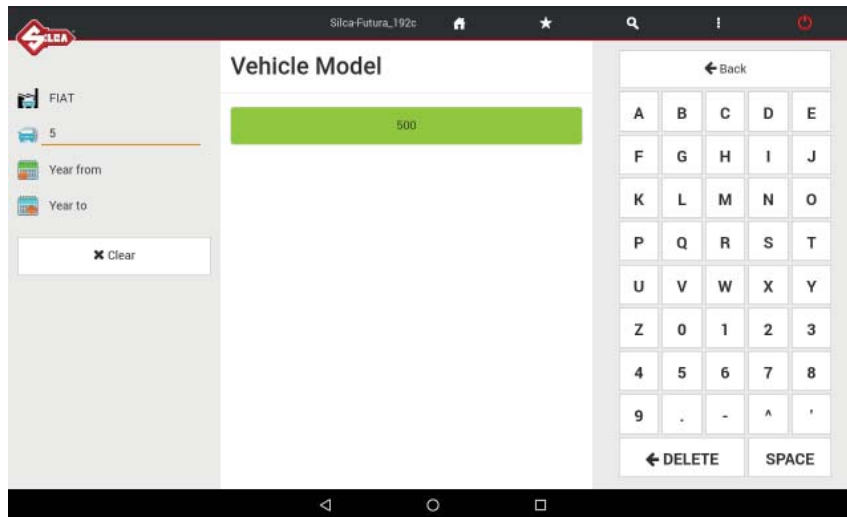

When the READ key has been hit, the sequence of operations is shown, with a drawing of the clamp and jaws to use and the Stop in use for the key in question. Tap START to continue.

Reading Original Key

Clamp	01R-01J-02J
STOP	0

Step by step guide

1. Open cover
2. Ensure that proper clamp settings are in place (see Clamp setting above)
3. **Carefully clean the clamp surfaces**
4. Install Tip Stop Tool if needed (see STOP setting above)
5. Clamp original key as shown
6. **REMOVE TIP STOP TOOL (if used)**
7. Lower Mobile Tracer
8. Lower the cover and press 'START'



Warning: Do not decode plastic keys.

START Cancel

Cutting Key

Clamp	01R-01J-02J
Cutter	02L
STOP	0
Pieces	<input type="text" value="1"/>

Step by step guide

1. Open cover
2. Raise the Mobile Tracer
3. **Remove customer key**
4. Carefully clean the clamp surfaces
5. Install Tip Stop Tool if needed (see STOP setting above)
6. Clamp new key as shown
7. **REMOVE TIP STOP TOOL (if used)**
8. Lower the cover and press 'START'



Clean the clamp

START Cancel

Cutting Key

Cutting key with card

Open shield and turn key to side 2

Step by step guide

1. Open cover
2. Carefully clean key and clamp surfaces
3. **Remove key**
4. Install Tip Stop Tool if needed
5. Turn key over and place uncut side up in clamp
6. **REMOVE TIP STOP TOOL (if used)**
7. Lower the cover and press 'START'

3 FAVORITE'S

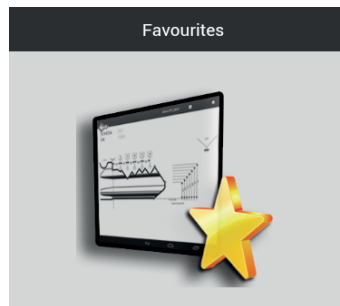

The FAVORITES menu contains the data cards that have been selected in the Search menu (Standard keys, Vehicle keys, Dimple/Track keys). Saving data cards to the favorites menu will eliminate the time spent searching for frequently used cards.

For each data card a description can be written in the special field in the “User Note” column.

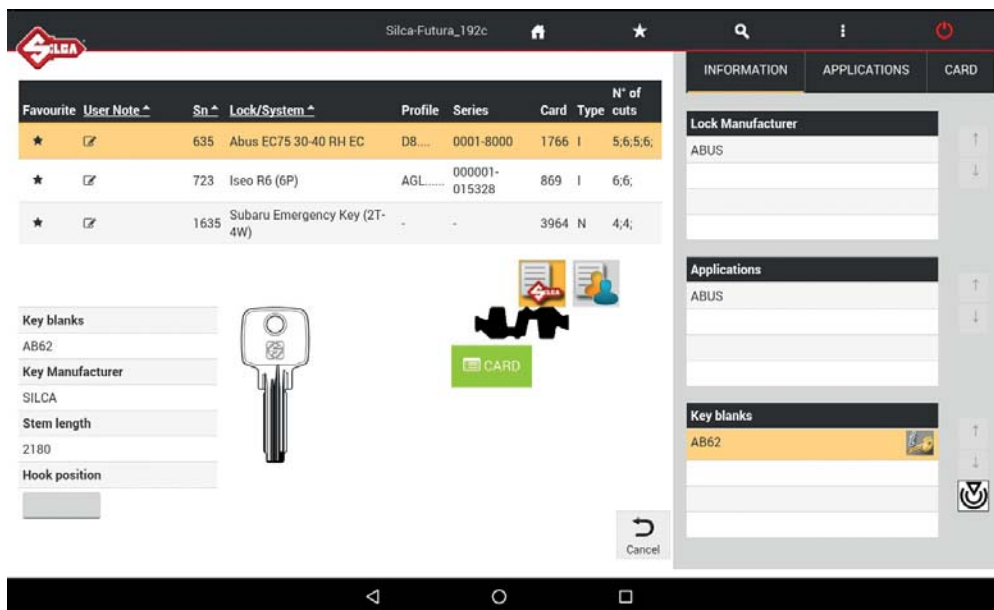

To select data cards to be included in the Favorite’s menu tap the star symbol ☆ in the first left-hand column of the Search menu; the symbol will be highlighted in black.

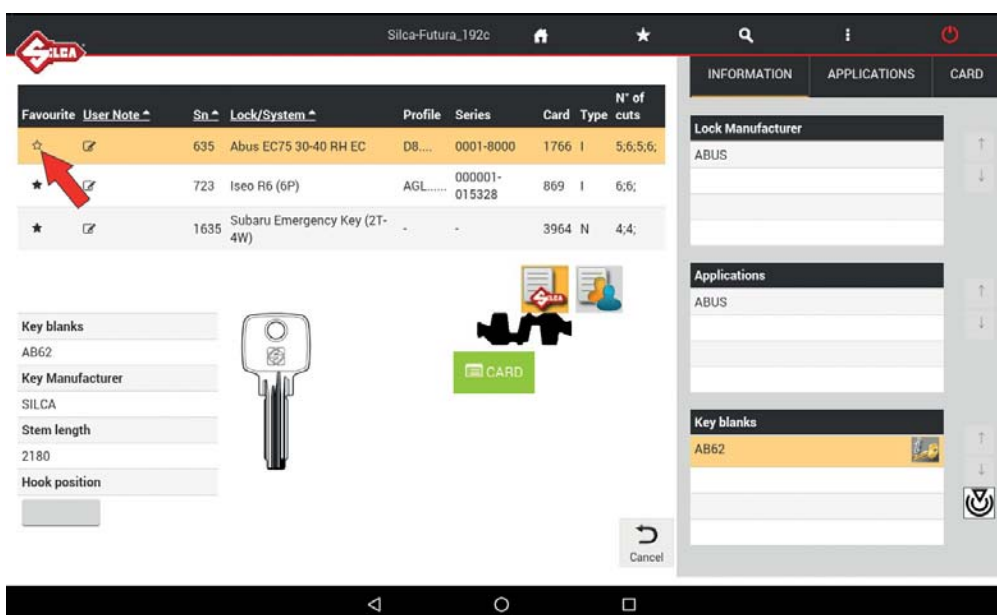

To remove a data card in the Favorite’s menu, tap the relevant star symbol, which will go back to white.

4 QUEUE OF JOBS

The “Queue of Jobs” collects all the jobs (the keys) the user prefers to do later. See on page 15 how to move a job in this “Queue of Jobs”.

4.1 “STANDARD” QUEUE OF JOBS

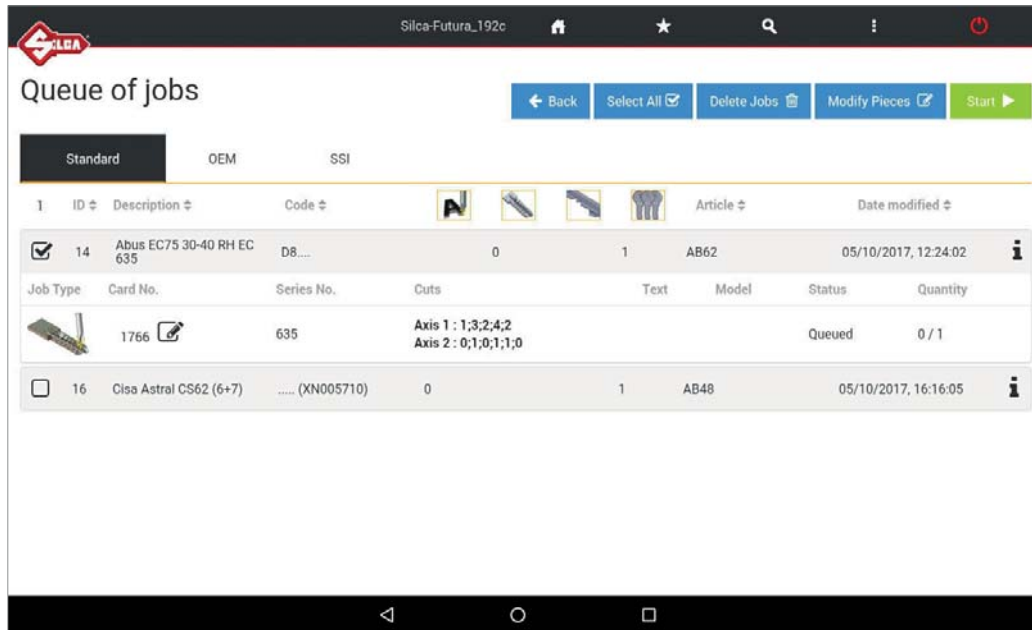

- Select one or more jobs using the “Select all” button, or tap the box.
- To see other job details, tap the single row.
- To delete the selected jobs, tap “Delete jobs”.
- To edit the number of keys to be cut in the selected jobs, tap “Modify Pieces”.
- To start cutting the selected jobs, tap “Start”.

ICON LEGEND

- Total number of keys to be cut
- Number of DIMPLE cuts already made
- Number of STANDARD cuts already made
- Number of ENGRAVINGS already done
- Identifies DIMPLE cuts
- Identifies STANDARD cuts
- Identifies ENGRAVING
- Extra information

4.2 “OEM” QUEUE OF JOBS (only with OEM CLIENT function enabled)

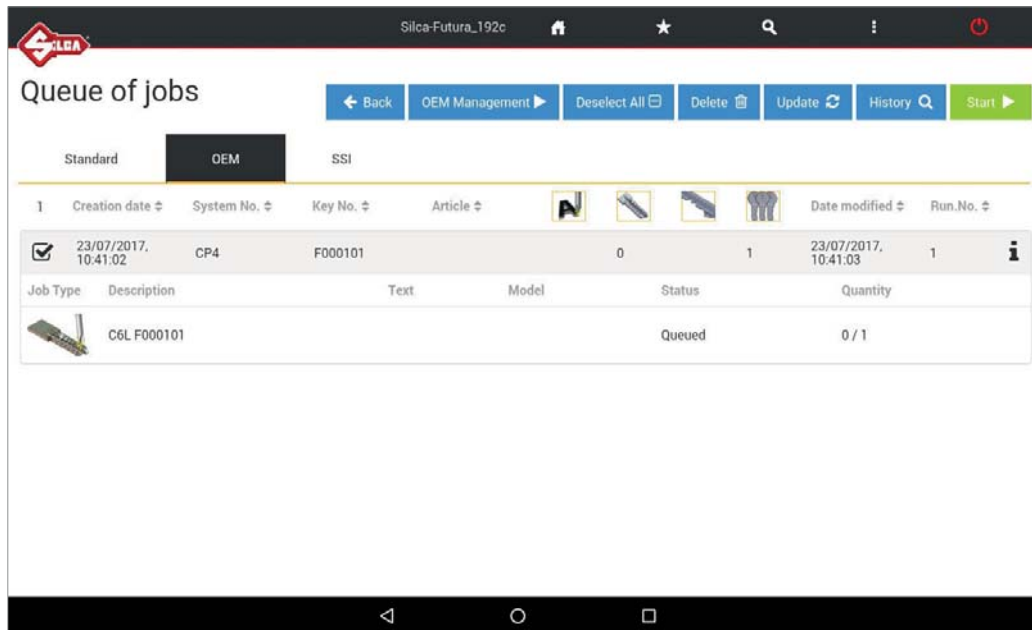

OEM jobs are copies of keys regulated by the manufacturer (OEM) through the OEM CLIENT function:

- **the manufacturer provides the information needed to cut the key.**
- **the manufacturer confirms the number of copies to make.**

When users have been authorised by the manufacturer and enabled by Silca, they can use the OEM CLIENT function to request and/or receive the data needed to cut the key and save them in the special OEM QUEUE. The OEM QUEUE function will guide the user through all the operations required to cut the key in a controlled, easy way.

According to the decision of the manufacturer, the jobs ordered may include:

- **a job to engrave a code on the head or stem of a key blank.**
- **one or more cutting operations.**

The user must carry out all the jobs defined by the manufacturer and follow instructions to the letter.

If an ENGRAVING job is included in the queue the user must have already created an ENGRAVING model with the same name and characteristics as the one proposed by the manufacturer. Otherwise no engraving job will be created. See the ENGRAVING section of the Software Guide (coming soon).

4.2.1 OEM CLIENT function activation

- Users who wish to use the special OEM CLIENT function must make a request to both the manufacturer and Silca. Consult the Silca sales network for information regarding which manufacturers allow this function to be used.
- When users have been authorised by the manufacturer and have applied to be enabled by SILCA they must unlock the OEM CLIENT function on board the machine by downloading a specific software update for their own FUTURA cutting machine.
- After the software update, check that enabling has been activated by selecting the INFORMATION window and checking the ENABLE OEMs section (Fig. 1).

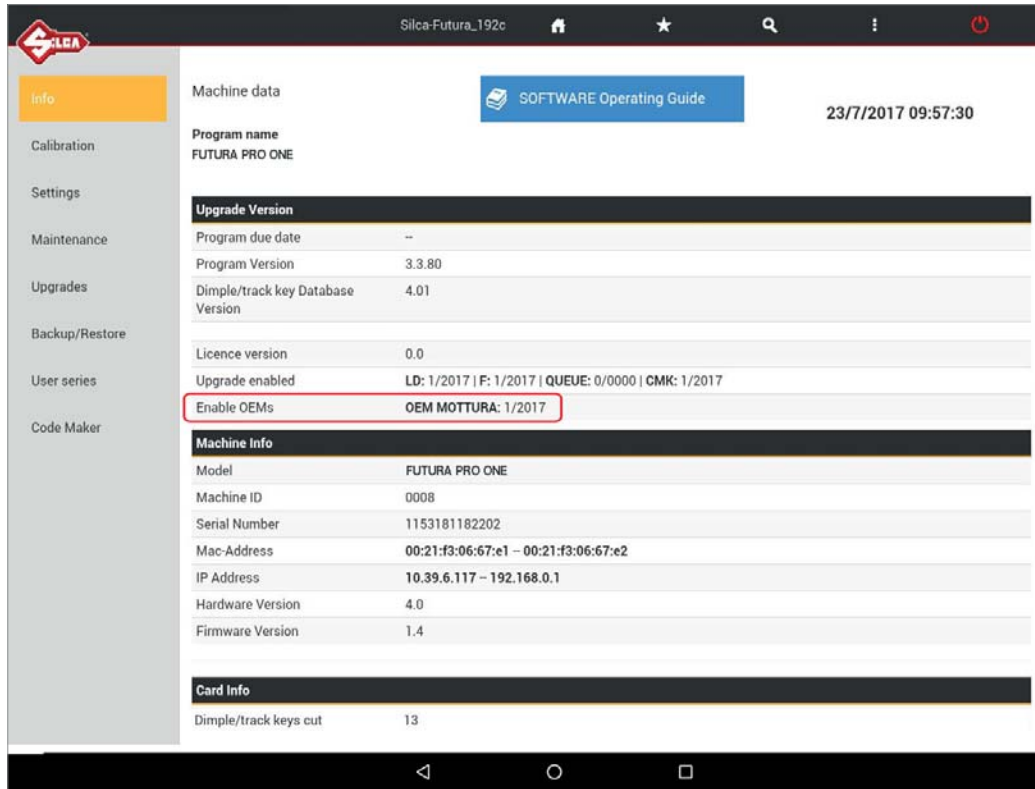

Fig. 1

IMPORTANT: for further details provided by each manufacturer about machine configuration and key cutting, consult the **ONLINE HELP** available in the **OEM QUEUE** -> "OEM Management" section.

4.3 “SSI” QUEUE OF JOBS

SSI jobs refer to master key systems (MKS). A .DAT or XML KESO file that can be imported to the machine by a USB PEN (FAT32) is required.

Insert the USB PEN containing the file/s into the key-cutting machine port. Tap ‘Open MKS’

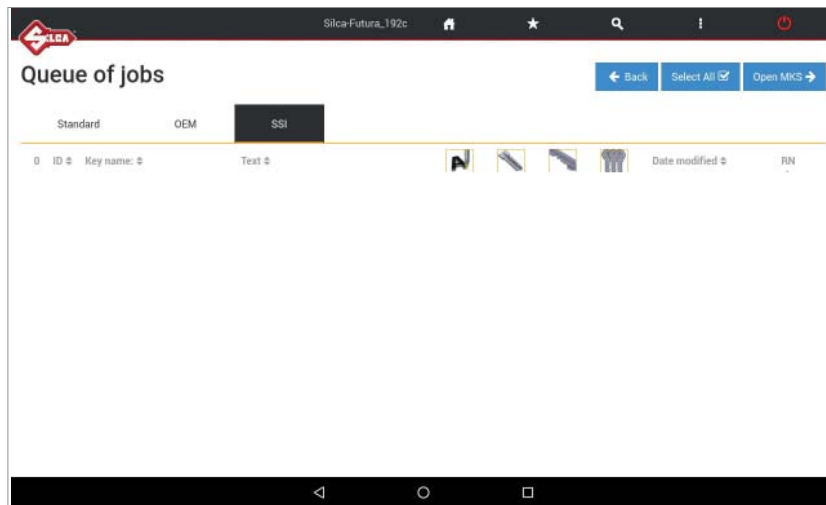

Select the required file and tap ‘Next’”.

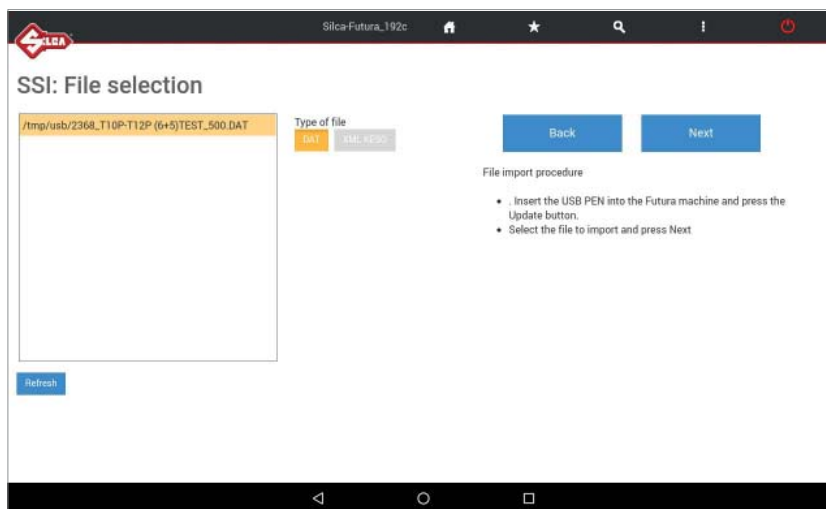

When the file has been properly imported, tap ‘Next’”.

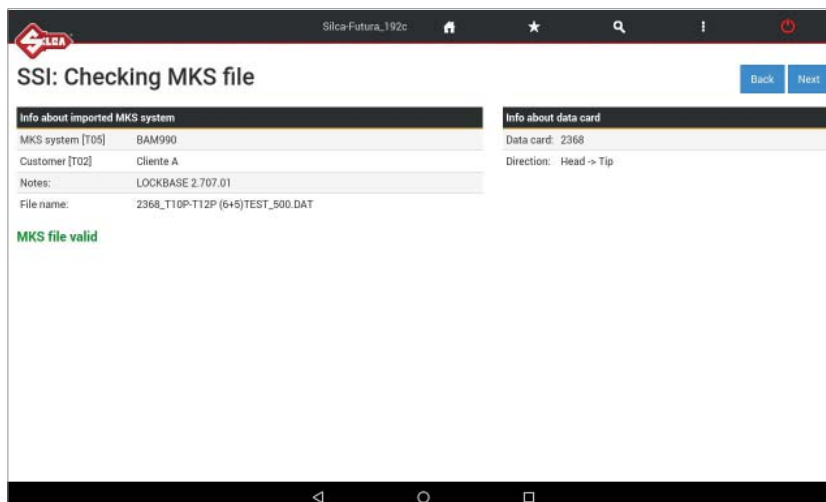

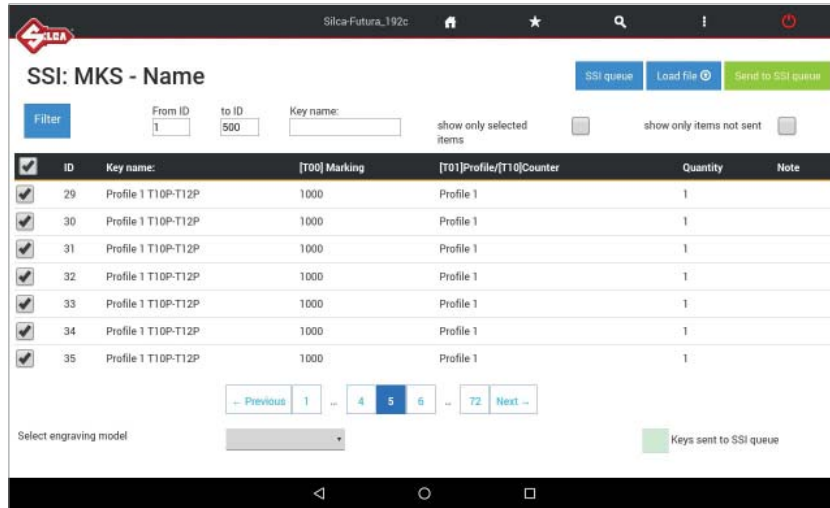

“MKS - Name” identifies the master key system and system name assigned by whoever generated the file.

Select the keys (lines) to be processed, and then tap “Send to SSI queue”.

Note: to select all the lines on a page, tap/check the left-hand ID box ID

Tap “Add” to send the jobs to the SSI queue.

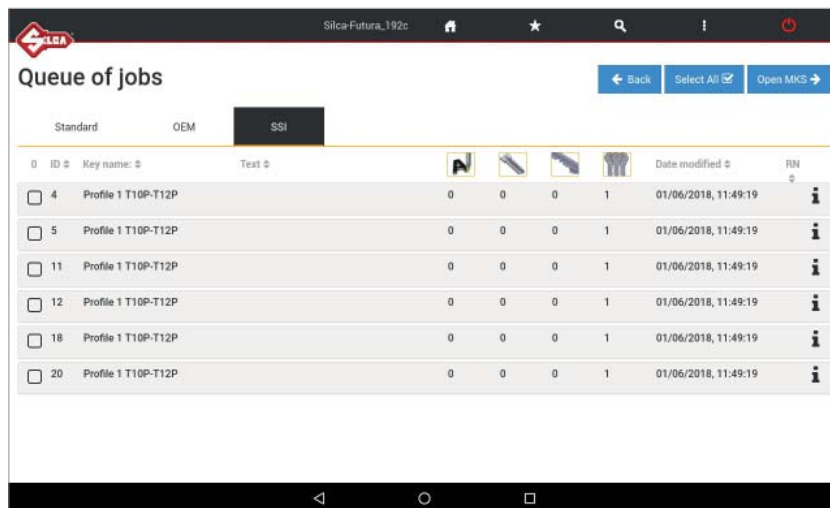
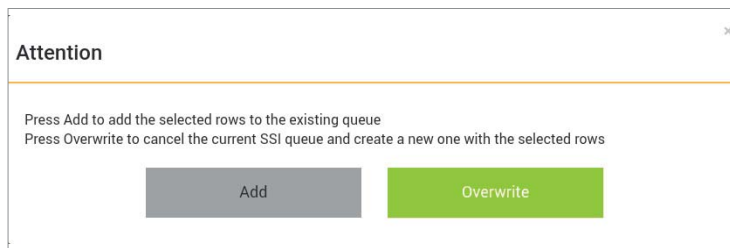

After the codes have been sent to the key-cutting machine, you can then select others. Tap “Open MKS”.

Note: the lines of keys already sent at least once to the SSI queue are highlighted in green.

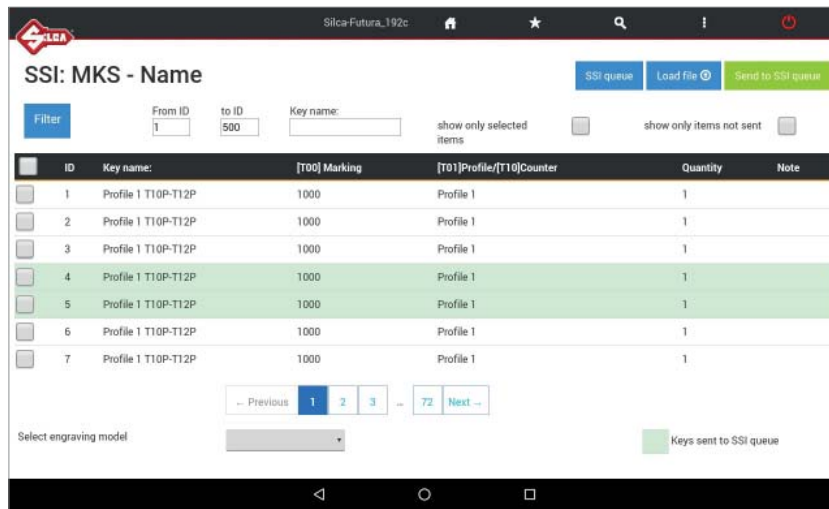

To facilitate a search for keys not yet sent to the SSI queue, tap/check “show only items not sent” and tap “Filter”.

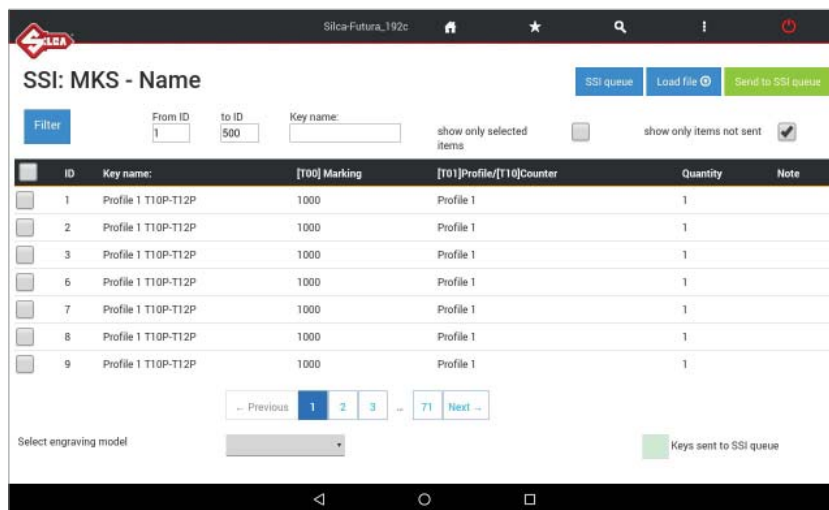

To facilitate a search for keys already selected, tap/check “show only selected items” and tap “Filter”.

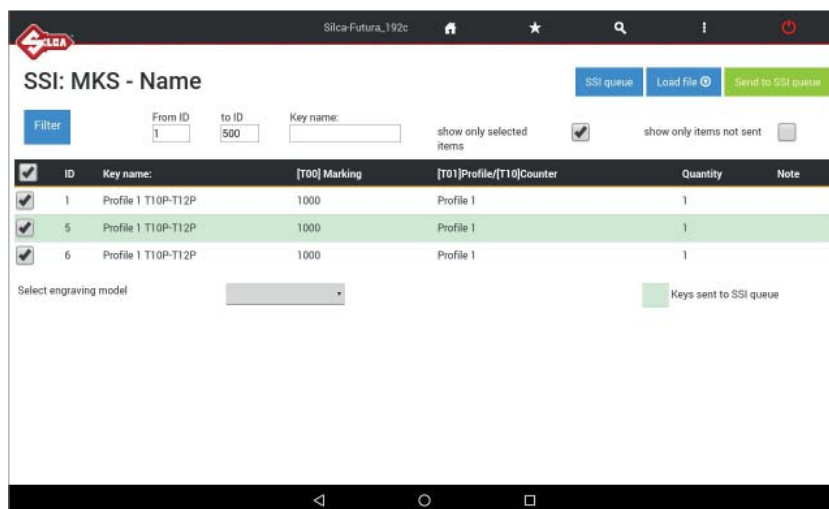

Engraving can also be run for or associated to each key, as long as a User model has already been created. Select the key, select the “Engraving Model” and tap “Send to SSI queue”.

Example:

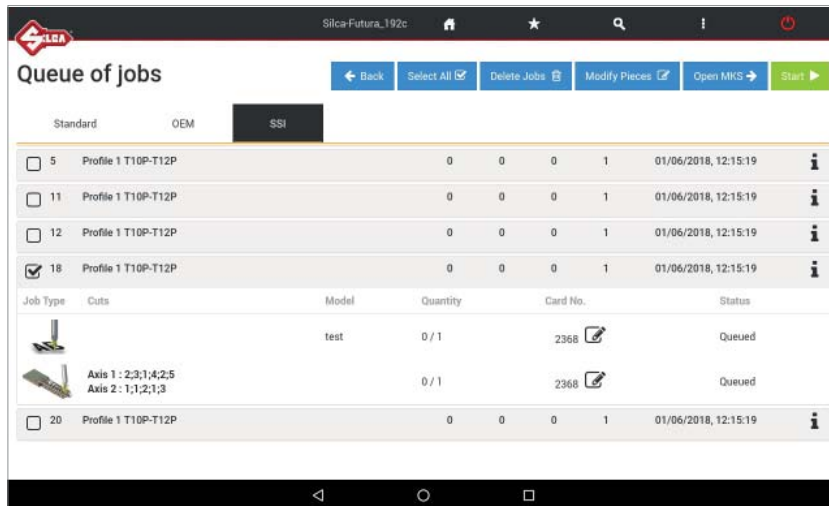
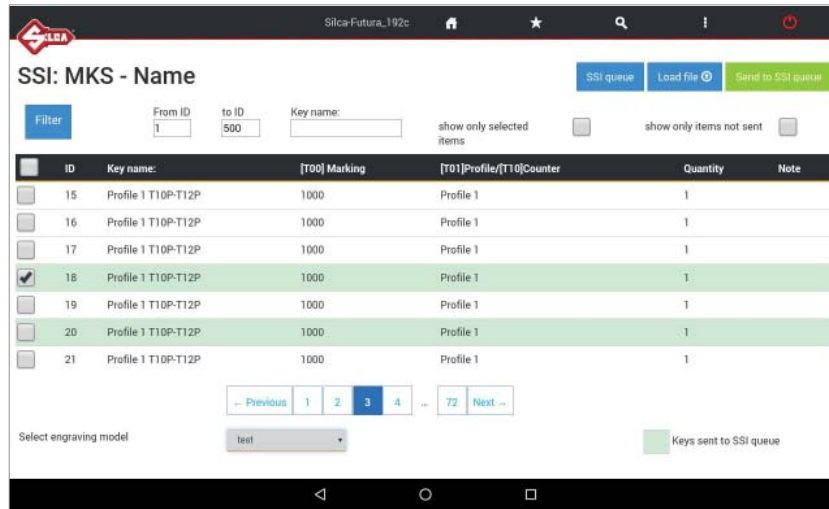

5 ENGRAVING

ATTENTION: function not enabled for FUTURA PRO ONE ABUS.

The ENGRAVING function software comes free for all FUTURA PRO ONE and FUTURA ONE key-cutting machine models.

The function is enabled by default. To disable and to hide certain engraving keys and fields, edit the parameter in the section:

OPTIONS menu -> Settings -> Options -> Preferences DIMPLE/TRACK keys

The ENGRAVING function requires the following OPTIONAL ACCESSORIES:

- **Jaw 01E (code D748737ZB)**
- **Jaw 02E (code D748739ZB)**
- **Adapter for plane 4 (code D750763ZB)**
- **Cutter 18DW specific for engraving (code D748741ZB)**

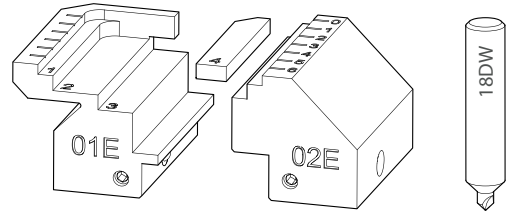
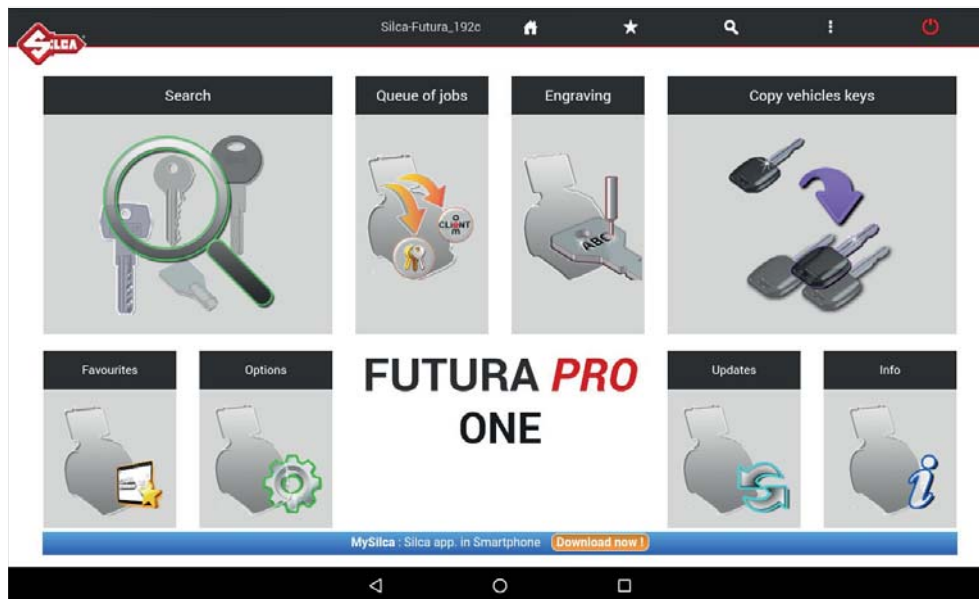
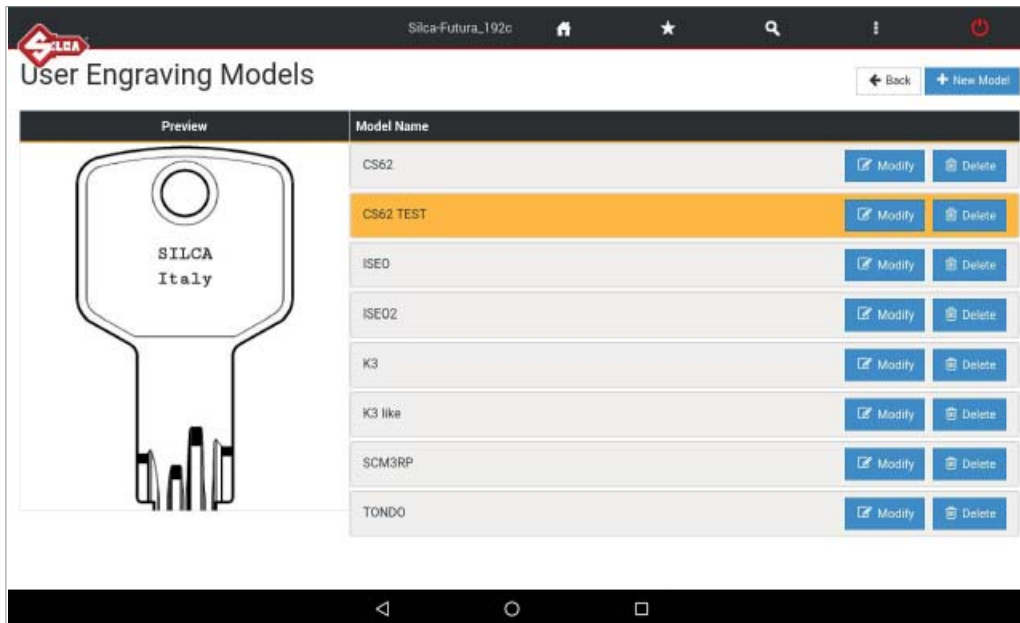

Fig. 2

Select the ENGRAVING icon to enter the list of ENGRAVING MODELS created by the User.





This makes it possible to:

- **CREATE** a new User Model
- **MODIFY** a User Model
- **DELETE** a User Model

Tap 'New Model' or 'Edit' to enter the User Model Editor function.

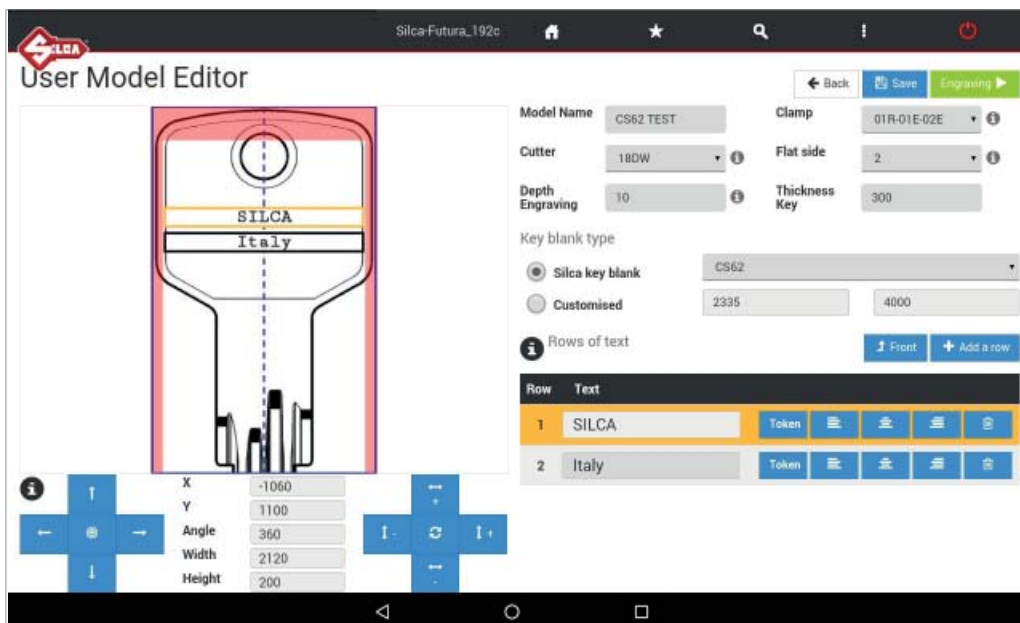

The ENGRAVING model defines all the parameters the machine requires to engrave a text on a key head or stem or on flat surfaces such as medals or metal plates.

ATTENTION: objects MUST BE METAL, NOT STAINLESS STEEL. Materials such as wood, paper, plastic and ceramics cannot be engraved.

Make sure the surface of the object to be engraved is flat.

Model creation procedure:

• **GENERAL PARAMETERS**

- Assign a Model Name
- Select a clamp (default: 01R-01E-02E)
- Select a cutter (default: 18DW)
- Set engraving depth (default 10 hundredths of a millimetre)
- Set Thickness for the key or object to be engraved (max 520 hundredths of a millimetre)
- Select the PLANE on which to fit the object to be engraved, according to its dimensions.

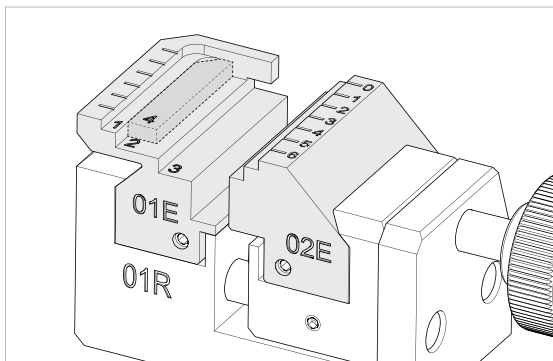

Fig. 3

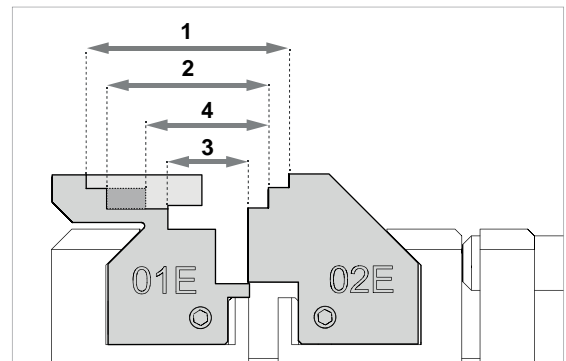

Fig. 4

PLANE	WIDTH of the object to be engraved	ENGRAVING AREA (L x H)
1	min 26 - max 32 mm	32 mm x 40 mm
2	min 20 - max 26 mm	24 mm x 36,5 mm
3	min 8 - max 14 mm	12 mm x 36,5 mm
4	min 14 - max 20 mm	18 mm x 36,5 mm

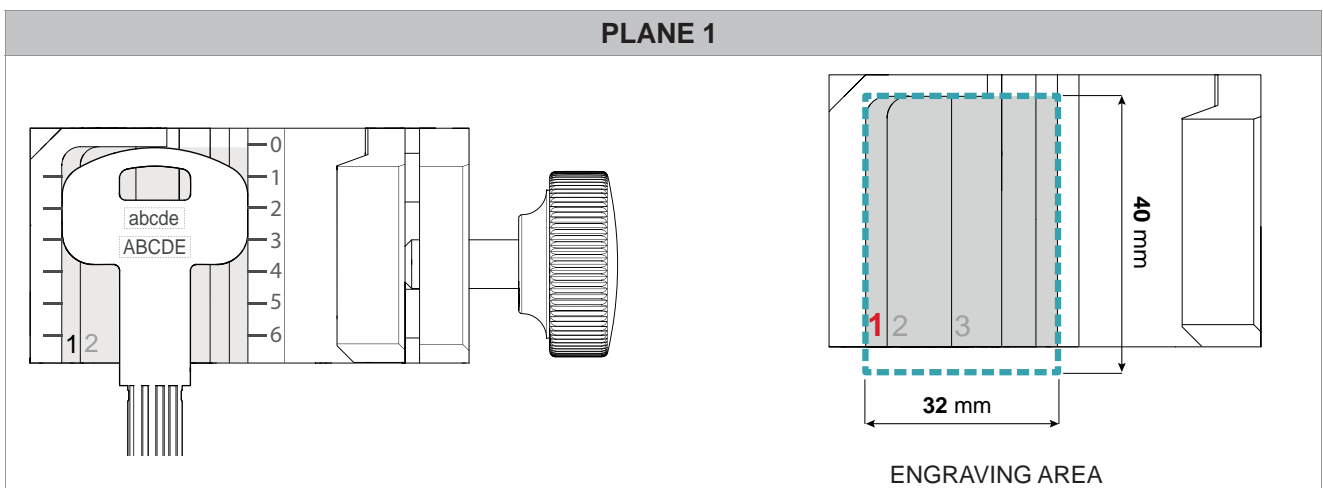

Fig. 5

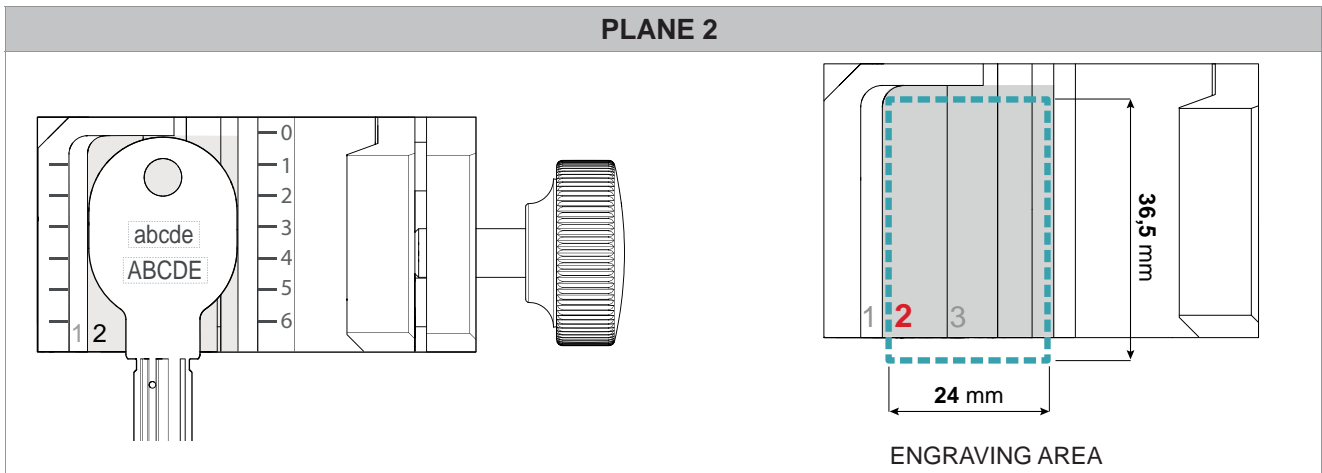

Fig. 6

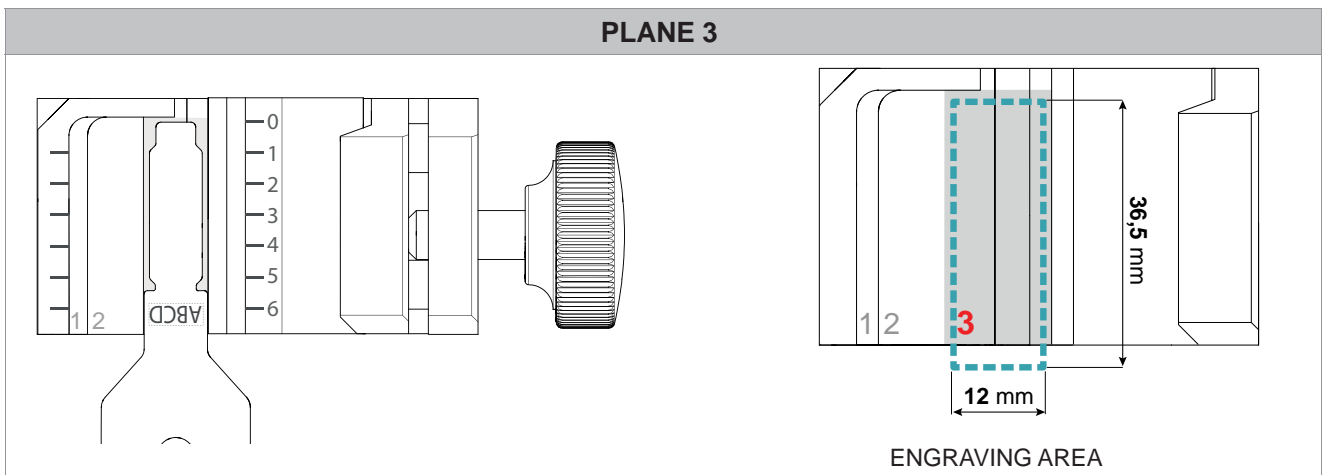

Fig. 7

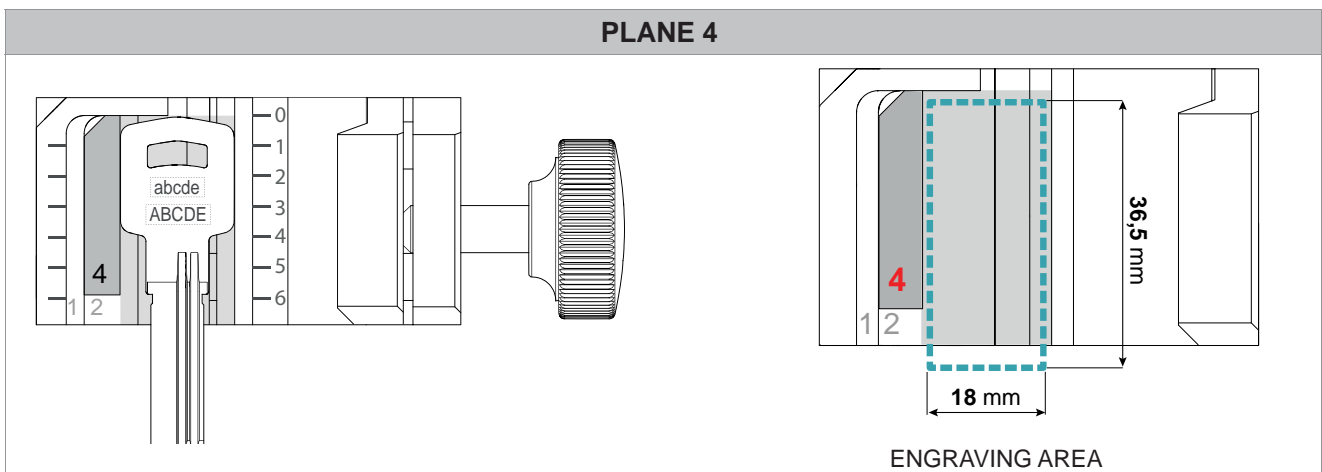

Fig. 8

- **TYPE OF OBJECT TO BE ENGRAVED (key or other)**

- Select '**SILCA key blank**' to choose a key blank similar to or the same as the SILCA one for which an example of an engraving Model has already been created.
- Select '**Customised**' to choose the dimensions of a circular or rectangular object to be engraved.

• **ROWS OF TEXT**

	To add the rows of text for one side only (FRONT) or both sides (FRONT and BACK) of the object to be engraved.
	To align the text R or L or CENTRE (default) for every row
	To remove the selected row of text.
	Select the TOKEN button to assign the 'type' to the current row. The 'type' of row may be a free text or a token. The token 'type' cannot be edited directly by the User, but is assigned suitable value with a figure available in the context of the model's use. E.g:

T [00]	Replaced with an INDIRECT cutting CODE
T [03]	Replaced with the PROFILE field for the lock system involved
T [04]	Replaced with the SERIES field for the lock system involved

Tokens are mainly used for OEM applications or the production of master key systems for which files containing special information are provided, as below:

T [00]	Replaced with the name or number of the key in a master key system
T [05]	Replaced with the number or name of a master key system
T [10]	Replaced with the 'Progressive Counter' field for a key in a master key system

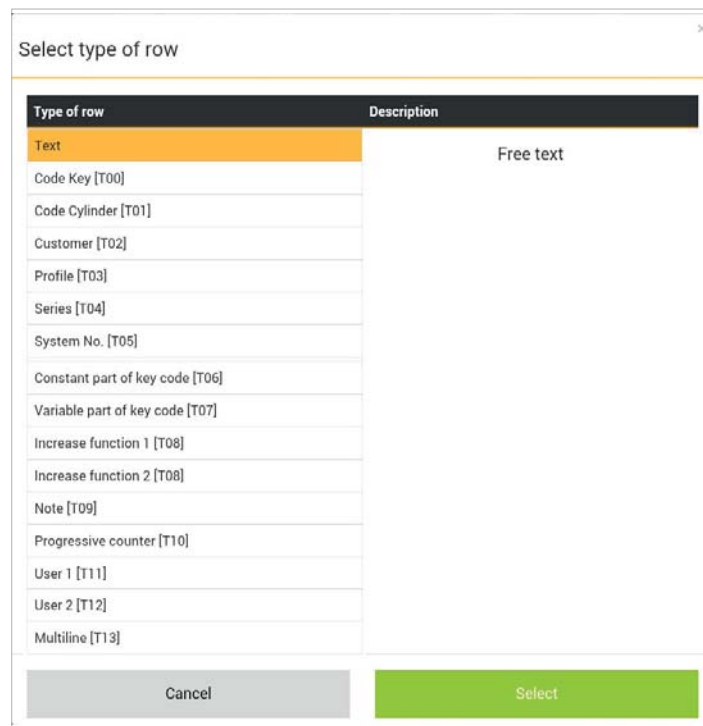

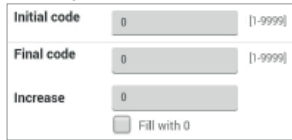
Text	Free text
T[00]	Replaced with an INDIRECT cutting CODE or Replaced with the name or number of the key in a master key system
T[01]	Used for special applications
T[02]	Replaced with customer Name assigned to a master key system
T[03]	Replaced with the PROFILE field for the lock system involved
T[04]	Replaced with the SERIES field for the lock system involved
T[05]	Replaced with the number or name of a master key system
T[06]	Replaced with the constant part of an INDIRECT cutting CODE
T[07]	Replaced with the variable part of an INDIRECT cutting CODE
Increase Function 1	<p>A progressive number is printed on the basis of the set parameters. The numerical sequence can be filled by zeros to maintain the width of the text unaltered.</p> <p>Example:</p>  <p>- 01 - 02 - 03 - ..</p>
Increase Function 2	<p>A sequence of progressive numbers linked to the set pieces is printed. Used to mark all the keys in sequence before cutting them. The numerical sequence can be filled by zeros to maintain the width of the text unaltered.</p> <p>Example:</p>  <p>setting a quantity of 2 results in:</p> <p>- 01 - 01 - 02 - 02 - 03 - 03 - .. - 10 - 10</p> <p>To obtain this result, when 2 pieces are finished, repeat the operation until the required sequence is ended.</p>
T[09]	Replaced with a note field for a master key system
T[10]	Replaced with the 'Progressive Counter' field for a key in a master key system
T[11]	Used for special applications
T[12]	Used for special applications

T[13]	<p>MULTILINE</p> <p>Select a token <input type="text" value="Select a token"/></p> <p>Position of first character to be engraved <input type="text" value="1"/> [1-99]</p> <p>Number of characters to be engraved <input type="text" value="1"/> [1-99]</p> <p>Employed to distribute a token (long text) over a number of lines by using token T13 twice or more. Once a token has been selected from T00 to T12 indicate:</p> <ul style="list-style-type: none"> • the position of the first character to be engraved • the number of characters to be engraved <p>Example:</p> <ul style="list-style-type: none"> • Token selected: T00 (indirect code - ABCD12345678) • Position of first character: 1 • Number of characters: 6 • Value to be engraved on key: ABCD12 <p>To complete engraving of the indirect code on a second line (with token T13):</p> <ul style="list-style-type: none"> • Position of first character: 7 • Number of characters: 6 • Value to be engraved on key: 345678
--------------	--

• **POSITIONING TEXTS WITHIN THE ENGRAVING AREA**

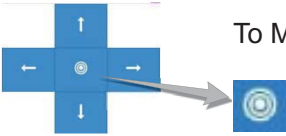

To **MOVE** the text area (right, left, up, down).

Centre button for **CENTRING** the text area inside the engraving area.

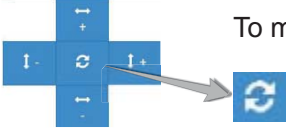

To make the height or width of the text area **SMALLER** or **LARGER**.

Centre button for **ROTATING** the text area by increases of 90°.

X	<input type="text" value="-1060"/>	To fine tune positioning and dimensions of the row of text, all the measurements viewed can be edited.
Y	<input type="text" value="1100"/>	
Angle	<input type="text" value="360"/>	
Width	<input type="text" value="2120"/>	
Height	<input type="text" value="200"/>	

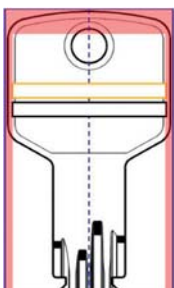

ATTENTION: the RED area corresponds to a safety zone which must be out of the tool's reach. Each clamp plane (1, 2, 3 and 4) has a different area. The User Model Editor monitors the position of the rows of text so that they do not interfere with the safety zone.

• HOW TO USE AN ENGRAVING MODEL

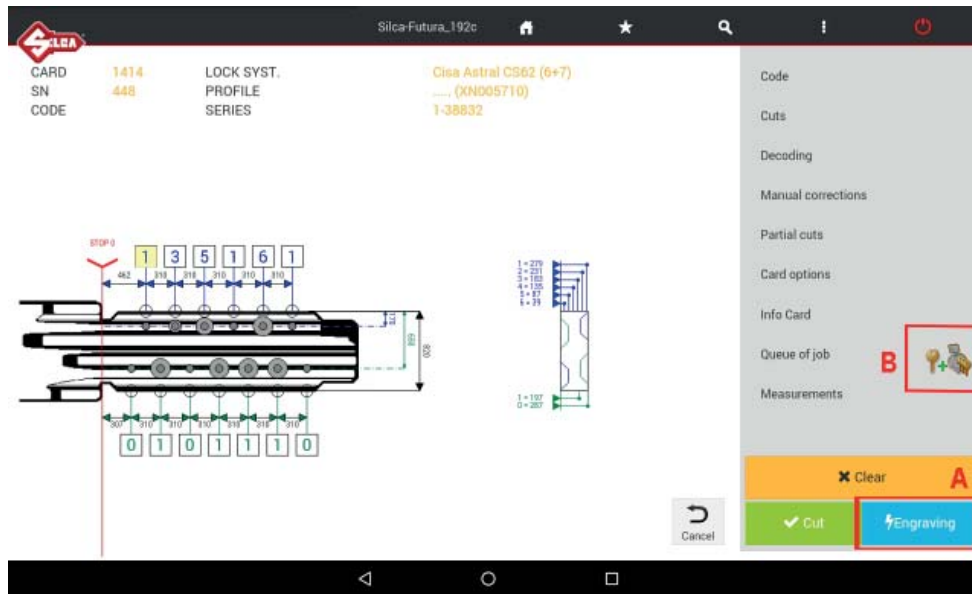

1) From a CUTTING CARD

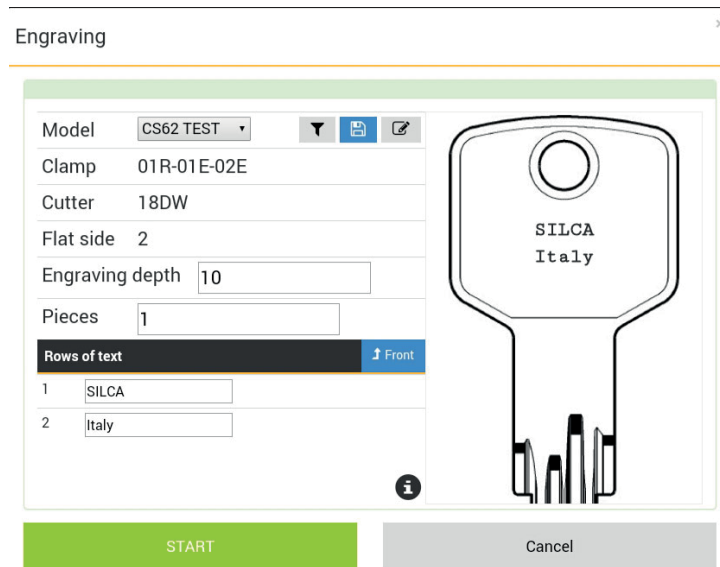

A - Tap ENGRAVING to view:



This window makes it possible to:

- Select a User Engraving Model or Predefined SILCA from the list and then associate it permanently with the cutting card by tapping 
- Filter the list of models so that it contains only USER MODELS + models relating to key blanks linked to the current cutting card by tapping 
- Edit the selected Model by tapping 
- Edit the number of pieces
- Temporarily edit the ENGRAVING DEPTH
- Temporarily edit the rows containing a free TEXT field
- Temporarily edit the Increase Function parameters

ATTENTION: the free text in a row and the 'Increase' function parameters can be edited, but the modifications are not saved.

ATTENTION: T[xx] tokens cannot be edited at this stage. Go back to the User Model Editor to change rows with Tokens.

ATTENTION: in the case of engravings created in an OEM job queue, many of the parameters listed above cannot be edited as the indications provided by the manufacturer must be observed.

B - Tap 'JOB QUEUE' with the ENGRAVING function enabled to produce:

The screenshot shows a dialog box titled "Add a job to the queue". At the top, it says "Select the type of job:" with two checked checkboxes: "Cut" and "Engraving". Below this are several input fields: "Model" (CS62 TEST), "Clamp" (01R-01E-02E), "Cutter" (18DW), "Flat side" (2), and "Engraving depth" (10). There is a "Rows of text" section with a "Front" button and two rows: row 1 contains "SILCA" and row 2 contains "Italy". To the right is a preview of a key with "SILCA Italy" engraved on it. At the bottom are "OK" and "CANCEL" buttons.

This screen is used to place either cuts or engraving in the queue, according to whether the user ticks the 'Cut' and/or 'Engraving' fields.

Further details are described in the section above.

2) Tap 'ENGRAVING' from the USER MODEL EDITOR.

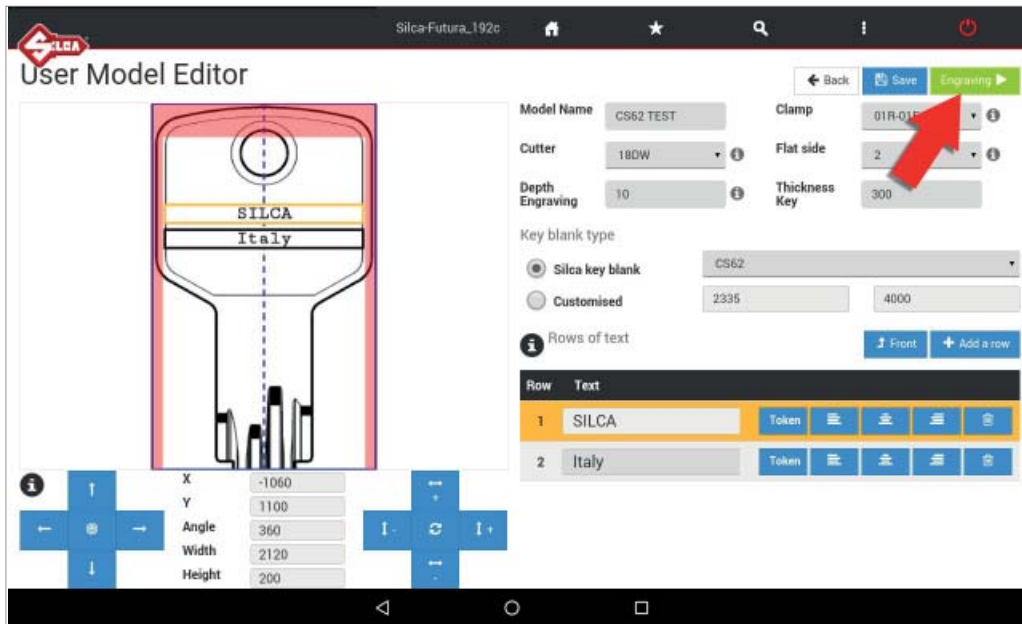

3) From JOB QUEUE

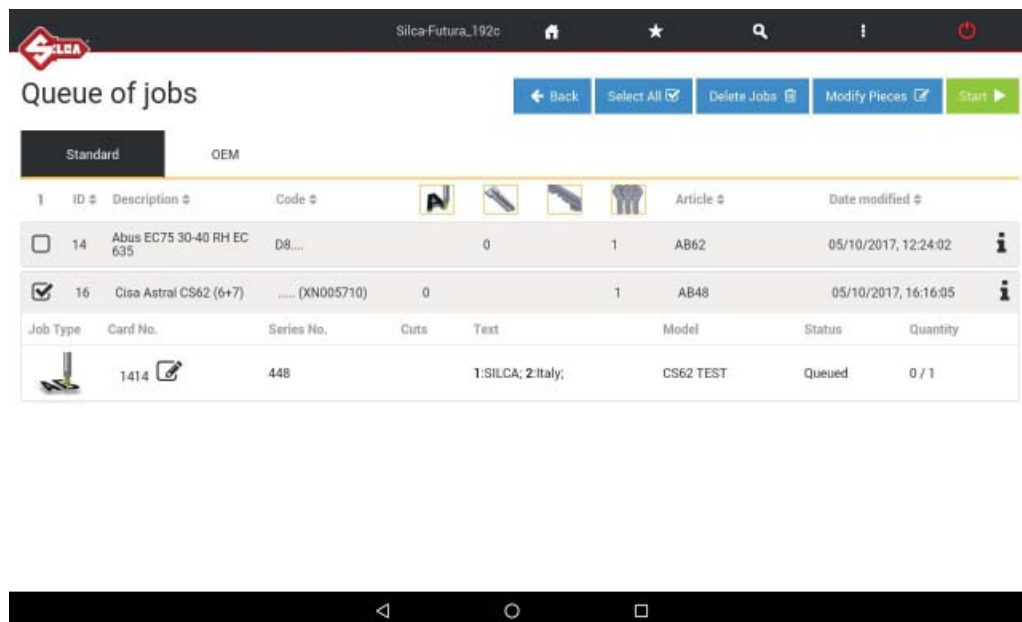

Further details are described in the section above.

6 OPTIONS



Options contains the following menus:

- **Info**
- **Calibration**
- **Settings**
- **Machine maintenance**
- **Upgrades**
- **Backup/Restore**
- **User series**
- **Code Maker (optional - see ch.10)**

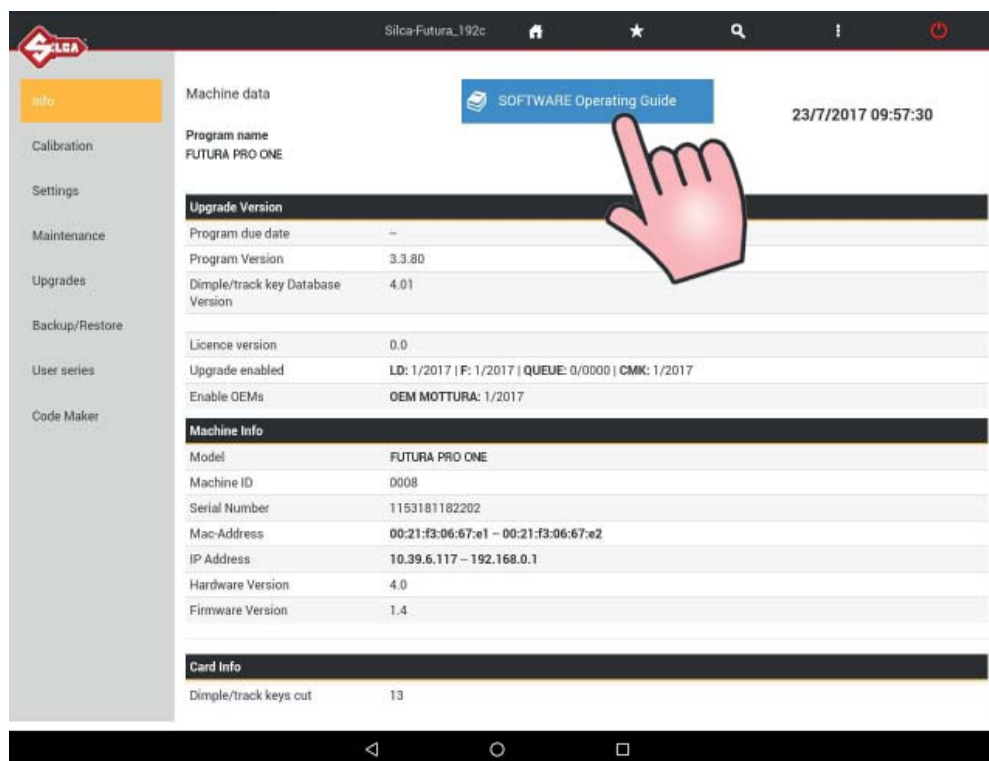

6.1 INFO

This window shows the main data for the Futura One / Futura Pro One machine (e.g. SW update version, serial number, number of keys cut, etc.).

Tap the appropriate icon to view the FUTURA PRO ONE “SOFTWARE OPERATING GUIDE”.
ATTENTION: this function is not available for FUTURA ONE.

6.2 CALIBRATION

Calibration includes:

- **Clamps Dimple/Track keys**
- **Mobile Tracer**
- **Dimple/Track key Adapter**

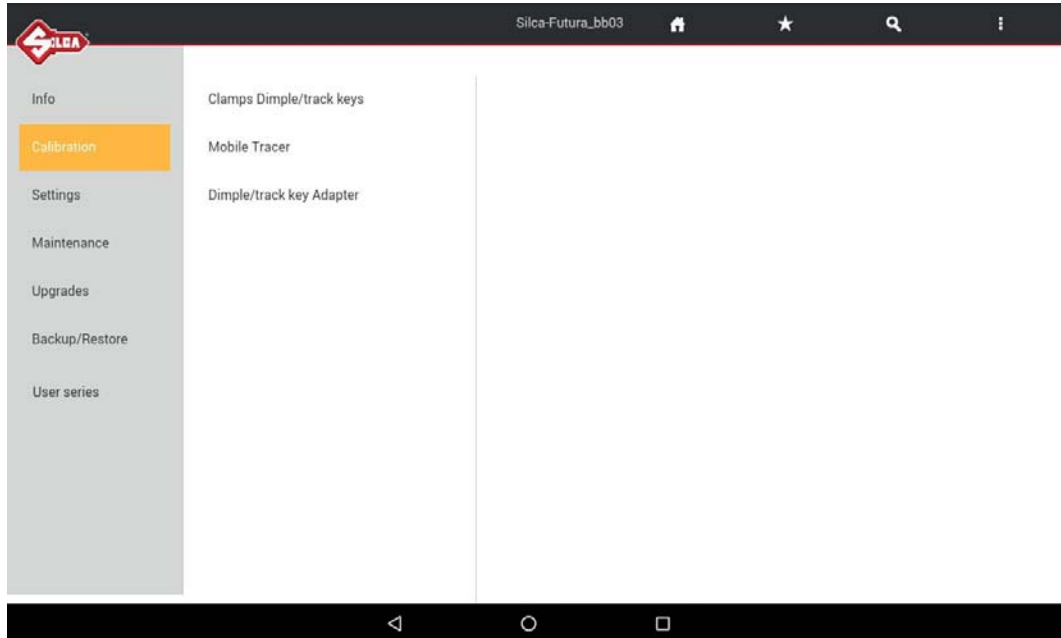

6.2.1 DIMPLE/TRACK keys clamp calibration

This menu contains a list of standard clamps and options for cutting these types of keys. Select the required clamp and tap START to begin calibration.

Use the 02T tracer for calibrating the clamps.

ATTENTION: to calibrate clamps with ...J jaws make sure the jaws are closed completely before proceeding.

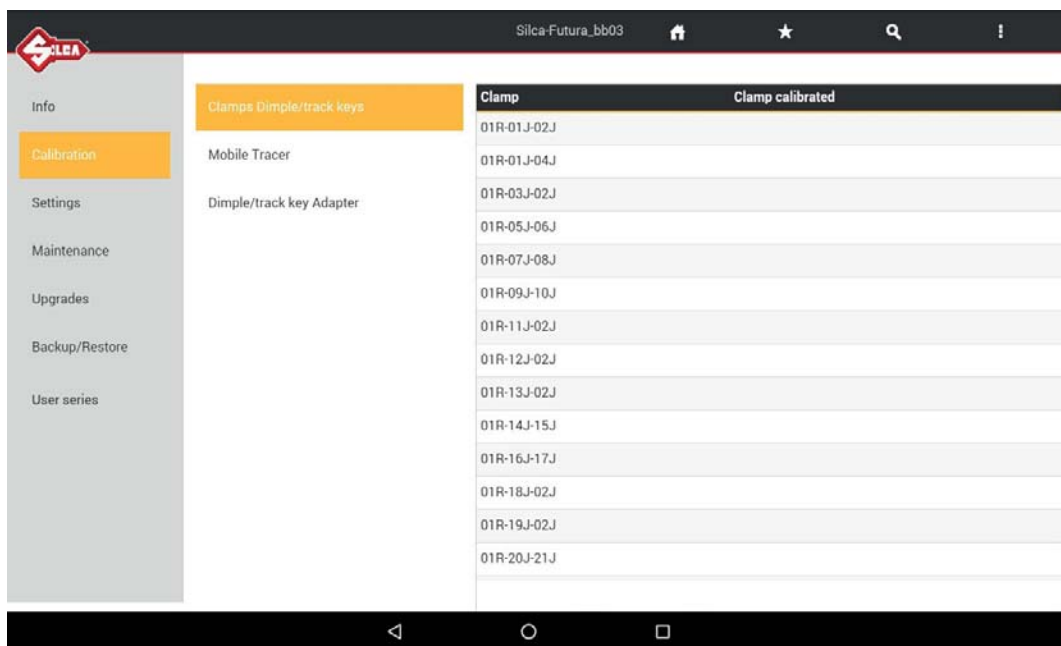

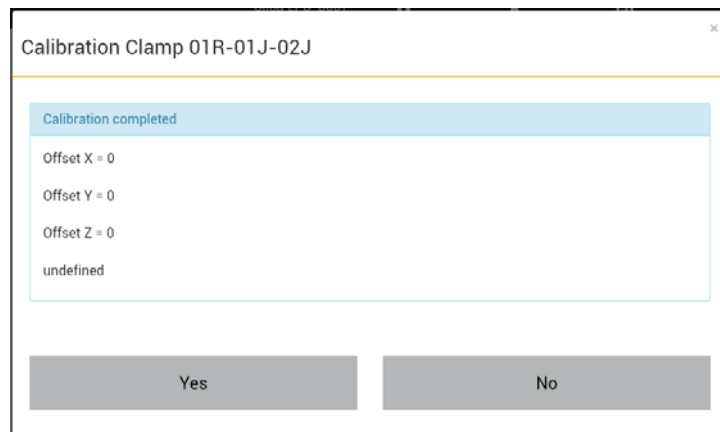
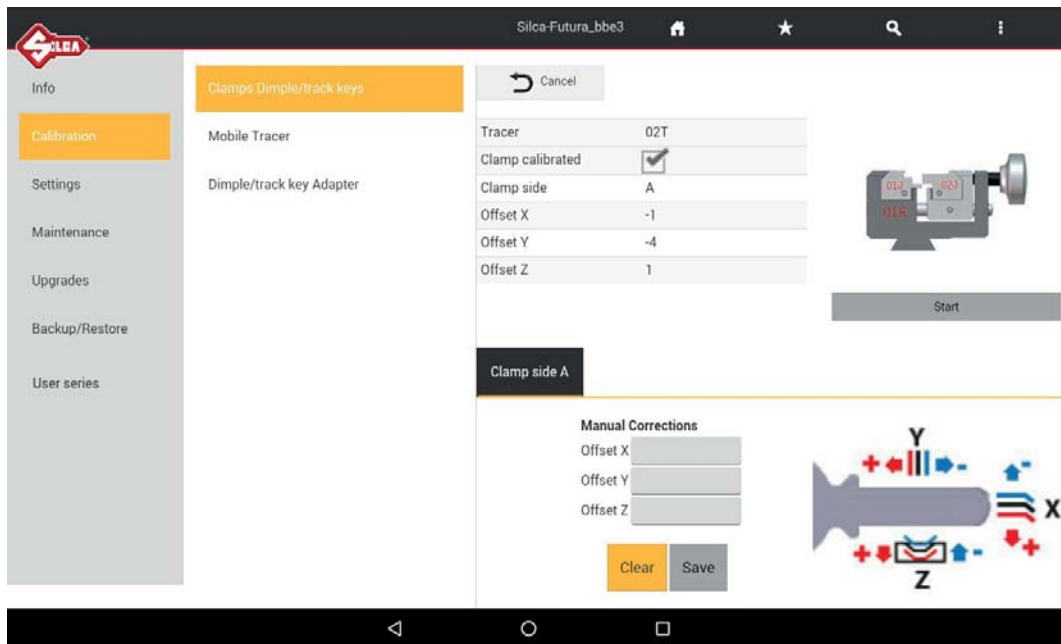

At the end of the operation you are required to save the data entered. Tap “Yes” to confirm.

MANUAL CORRECTIONS

Y, X and Z axis manual corrections can be applied if necessary.

Positive value of Y: takes cut closer to stop.

Negative value of Y: takes cut away from stop.

Positive value of X: moves cut to the right of the axis.

Negative value of X: moves cut to the left of the axis.

Positive value of Z: lowers the cut from the axis.

Negative value of Z: raises the cut from the axis.

Adjustments: from -30 to +30 hundredths of mm (+/- 118 thousandths of an inch)

Tap “Save” to confirm.

6.2.2 MOBILE TRACER 01T calibration

ATTENTION: when calibrating the 01T mobile tracer make sure the 01J-02J jaws are completely closed before proceeding.

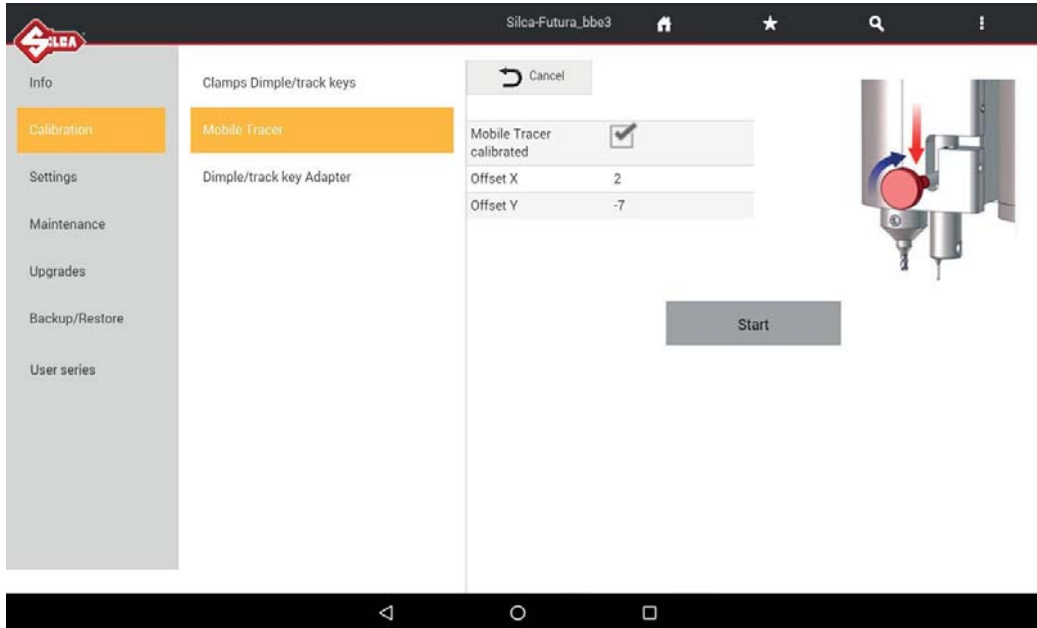

Lower the 01T mobile tracer and lock in place by turning the knurled knob clockwise. Tap START to begin calibration and follow the instructions on the screen. At the end of the operation you are required to save the data entered. Tap YES to confirm.

6.2.3 DIMPLE/TRACK keys Adapters calibration

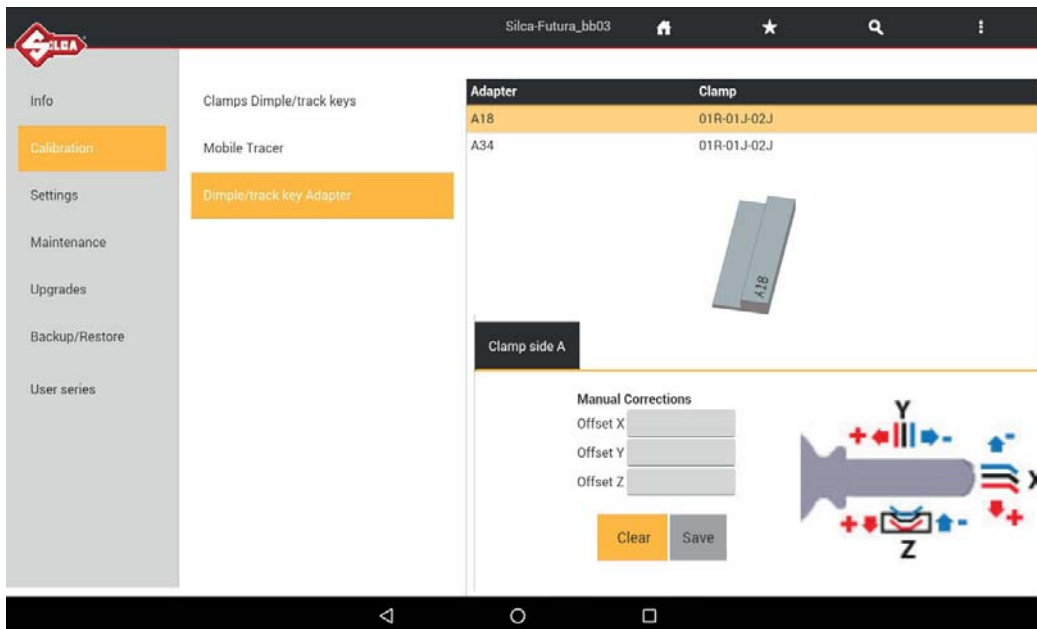

Positive value of Y: takes cut closer to stop.
 Negative value of Y: takes cut away from stop.
 Positive value of X: moves cut to the right of the axis.
 Negative value of X: moves cut to the left of the axis.
 Positive value of Z: lowers the cut from the axis.
 Negative value of Z: raises the cut from the axis.
 Adjustments: from -30 to +30 hundredths of mm) (+/- 118 thousandths of an inch)
 Tap "Save" to confirm.

6.3 SETTINGS

The Settings menu contains:

- **Zero-point Calibration (DIMPLE/TRACK key)**
- **Options**
- **Network setting**
- **Registration**
- **Import hooks position file**

6.3.1 Zero-point Calibration (DIMPLE/TRACK key)

This operation requires the use of the 02T tracer.

ATTENTION: make sure the jaws are completely closed before starting.

Tap START and follow the instructions on the screen.

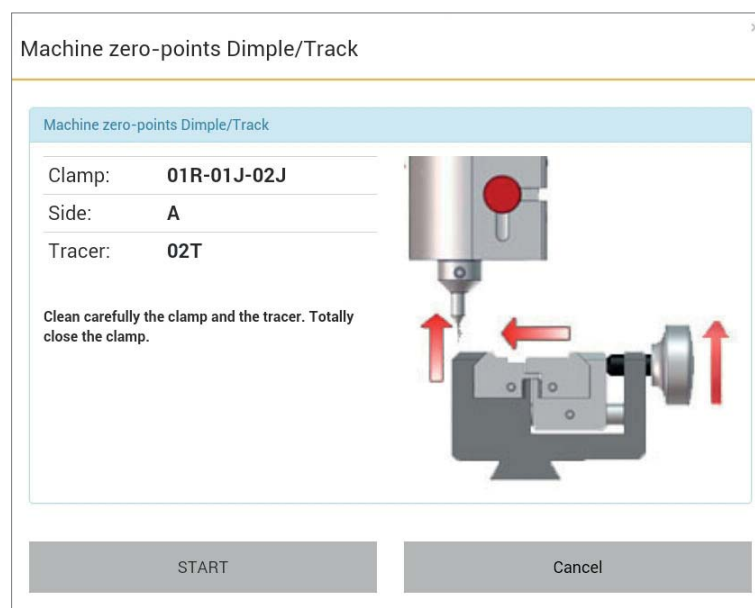
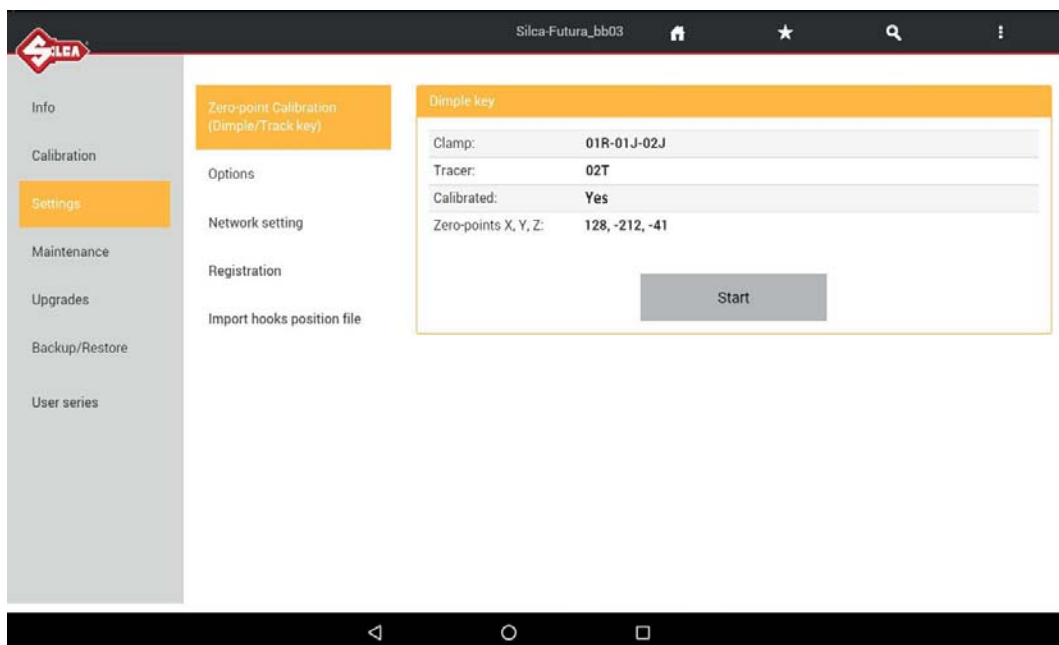

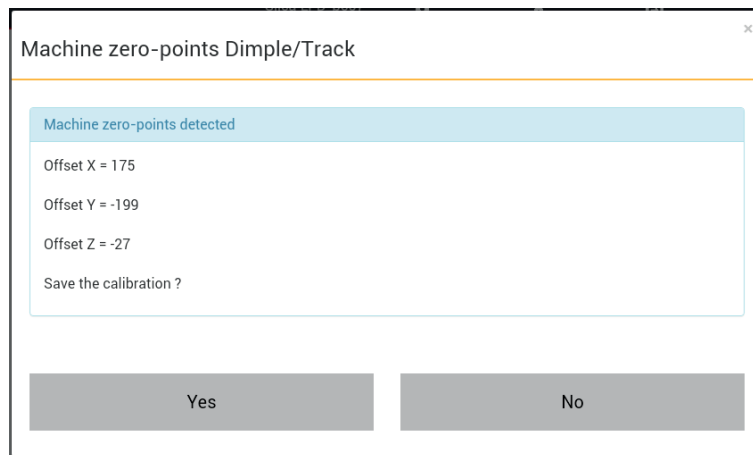
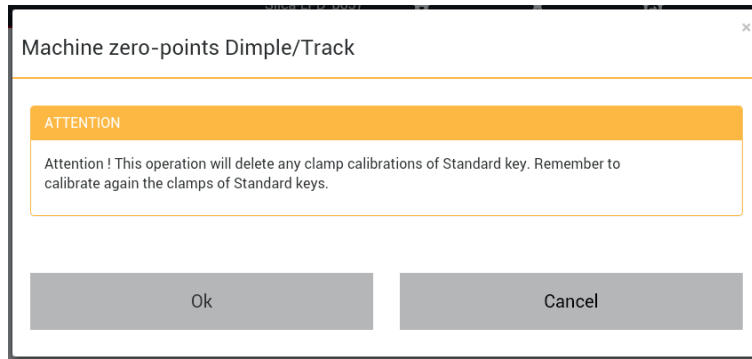

At the end of the operation you are required to save the data entered.
Tap "Yes" to confirm.

NOTE: Remember to replace the 02T tracer with the proper cutter prior to attempting to cut a key to prevent damaging the 02T tracer.

6.3.2 Options

The Options menu contains:

- **General**
- **Preferences DIMPLE/TRACK key**

6.3.2.a General

The following parameters can be modified:

- **Measurement Unit** (millimeters or inches)

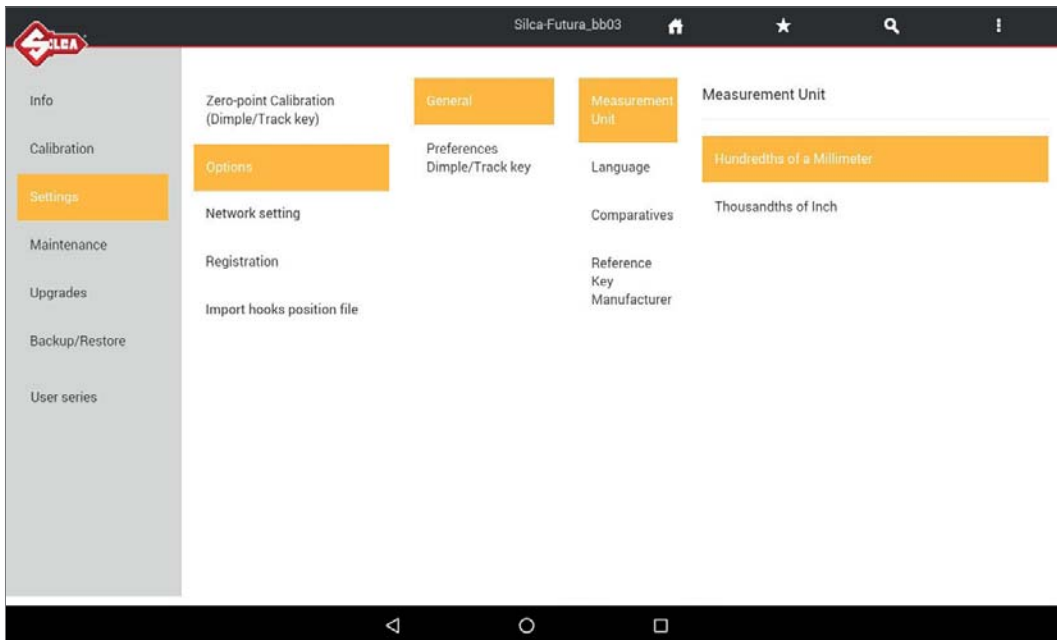

- **Language**

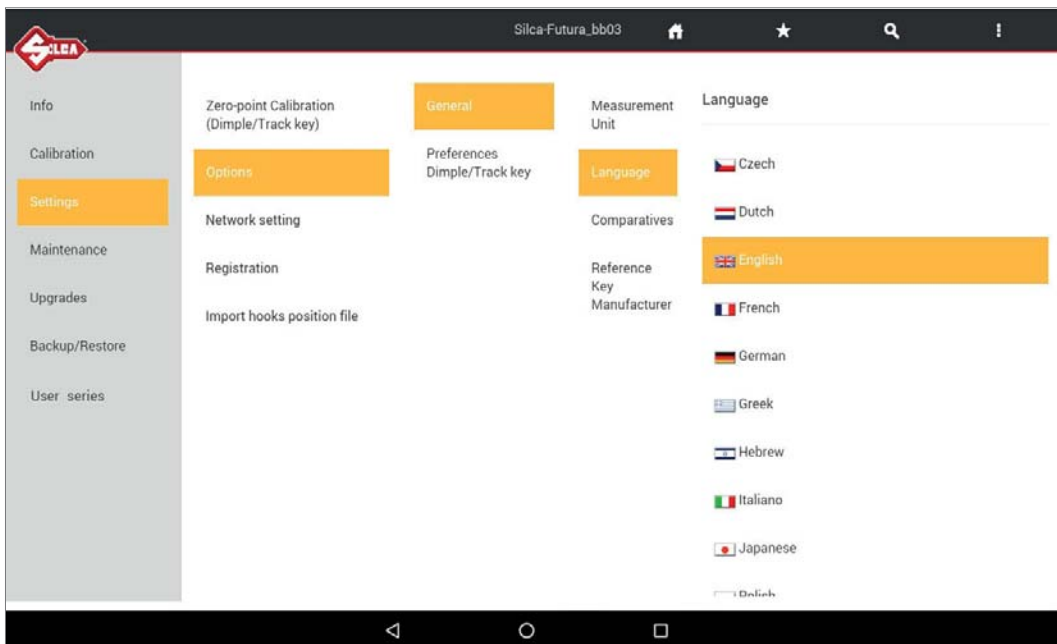

- **Comparatives** (comparative brands to visualize for key research)

It's possible to pick and/or unpick brands that can be seen after a research of comparatives articles. In the comparative list Silca is activated by default.

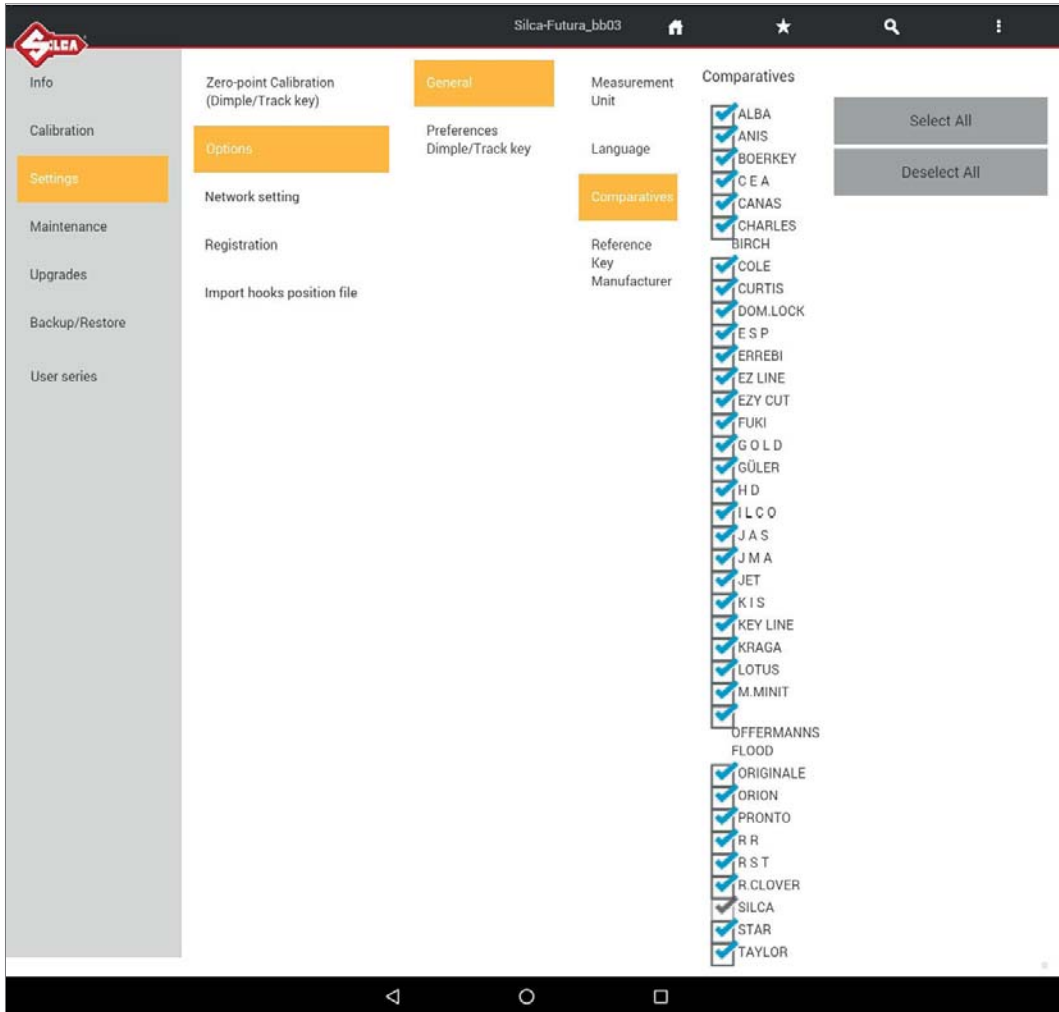

• **Reference Key Manufacturer**

After a key search... the key to be duplicated will always (with exception*) be the Silca reference by default. ILCO can also be set as a reference by default.

* keys that are not produced by Silca (copyright - obsolete - new keys)

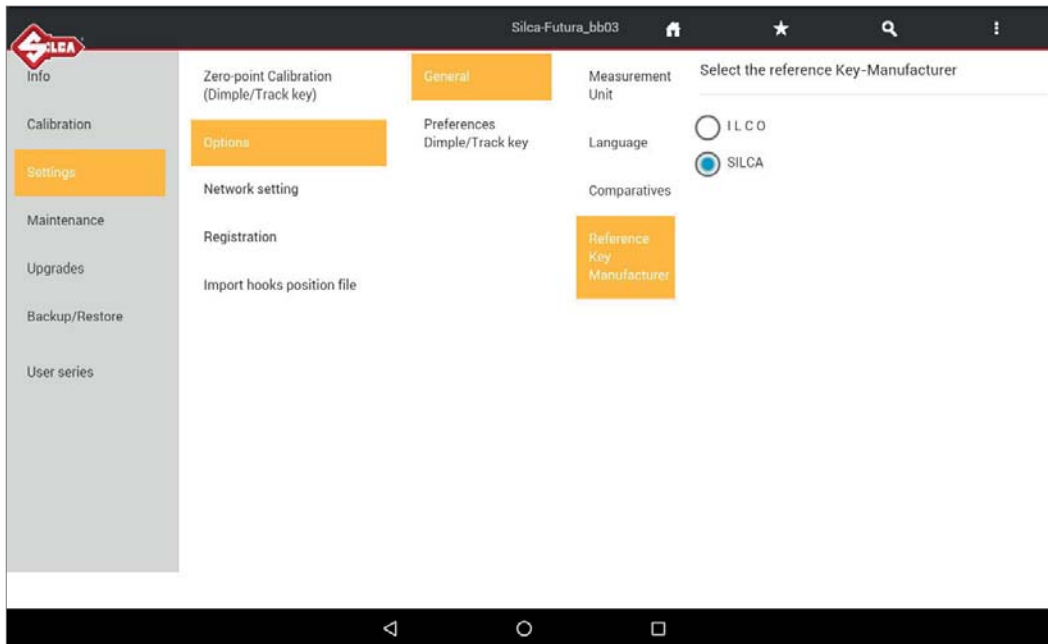

6.3.2.b Preferences DIMPLE/TRACK key

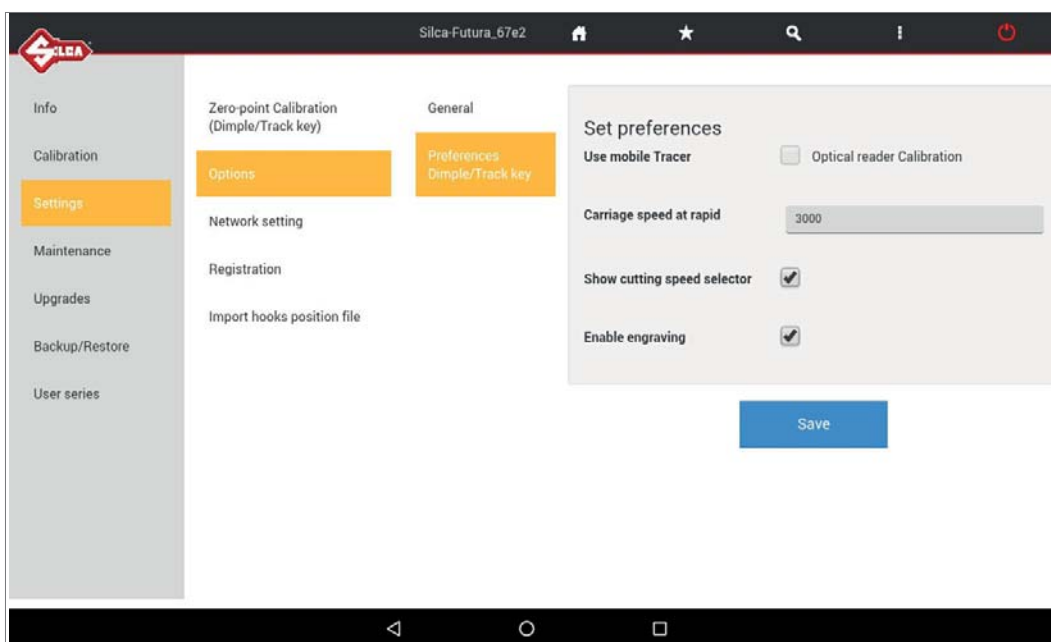

Set preferences: used to enable or disable the use of the 01T mobile tracer. If the field is not selected the 02T tracer is required, to be fitted into the shaft for the decoding operations.

Carriage speed at rapid: used to set the carriage speed for rapid movements; the pre-set value of 3000 is recommended by Silca.

Enable engraving: used to enable the ENGRAVING function wherever required, at any point in the program.

6.3.3 USE

The machine can be set up in one of the 4 modes below:

- 1) **ACCESS POINT** through Wi-Fi (factory configuration)
- 2) **ETHERNET** with connection to LAN and router (to connect the machine to the internet)
- 3) **TETHERING USB** (for connecting tablet and machine via cable)
- 4) **LOCAL NETWORK (LAN)** (to connect the machine to the internet)

MODE	ACCESS TO INTERNET	TABLET - MACHINE Connection 	Recommended
ACCESS POINT	NO	Wi-Fi	YES
ETHERNET with connection to LAN	YES via CABLE	Wi-Fi	YES
TETHERING USB	NO	USB cable	YES
LOCAL NETWORK	YES via Wi-Fi	Wi-Fi	-

6.3.3.a ACCESS POINT mode (Wi-Fi connection between machine and Tablet)

In this mode the Tablet connects directly to the machine.
 The machine is set on this mode in our workshops.



Fig. 9

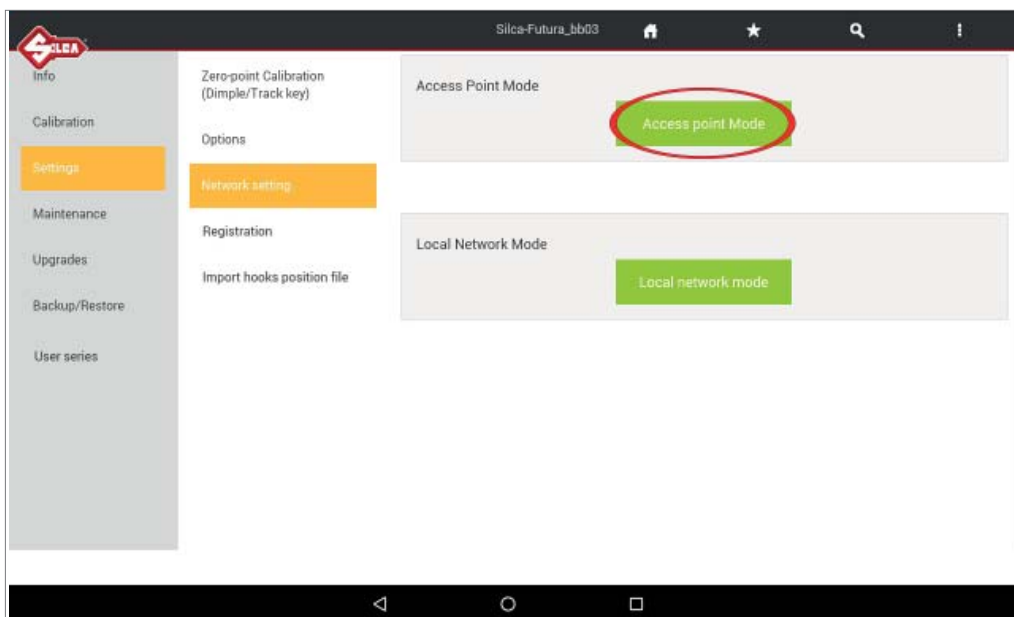

When the machine and Tablet are switched on the connection automatically activates in around two minutes; if not, check the Wi-Fi connection from your Tablet to see if the machine is included in the Wi-Fi networks that are found; the machine will appear as **Silca-Futura_....**

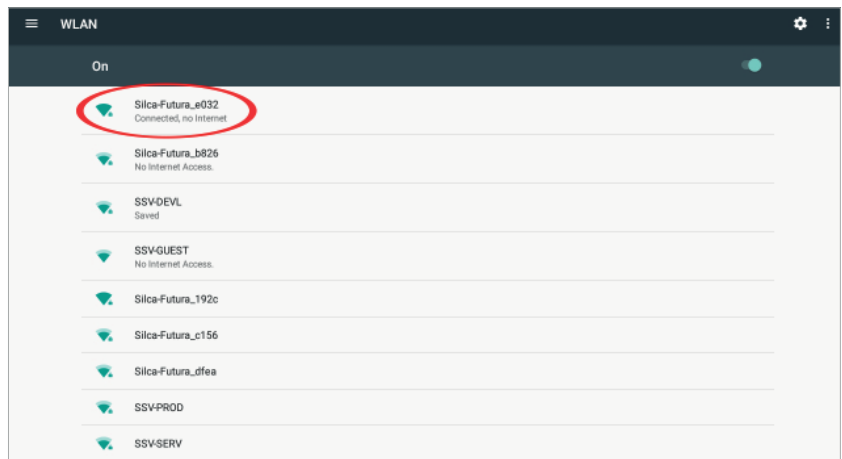
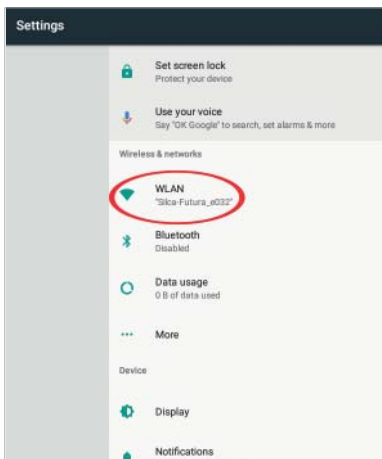

If it is not connected pick “Silca-Futura_...” and input the password which correspond to the machine serial number (made up of 13 numbers).

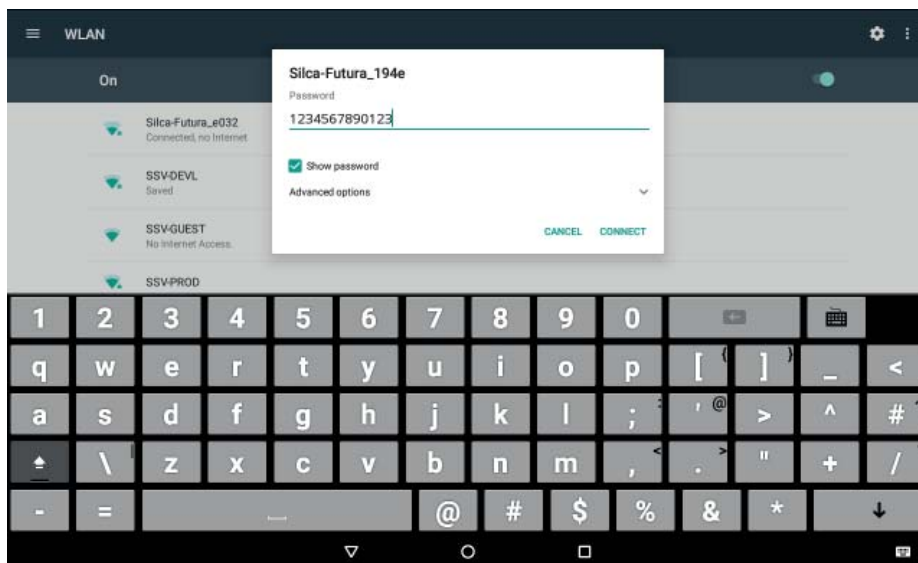

The option to change the Wi-Fi channel is used in cases when the (point to point) communication cannot be properly connected since there are too many devices tuned to the same channel. It also permits the user to adapt to the rules and restrictions of Wi-Fi channel use in their country. To change the channel one must first be connected, select the new channel and then reboot the machine.



6.3.3.b ETHERNET with connection to LAN and router

To connect the Futura One / Futura Pro One key-cutting machine to the internet through your LAN:

- Set the machine on ACCESS POINT and connect the tablet in Wi-Fi to the machine (factory configuration).
- Connect your LAN ethernet cable to the machine (Fig. 10).

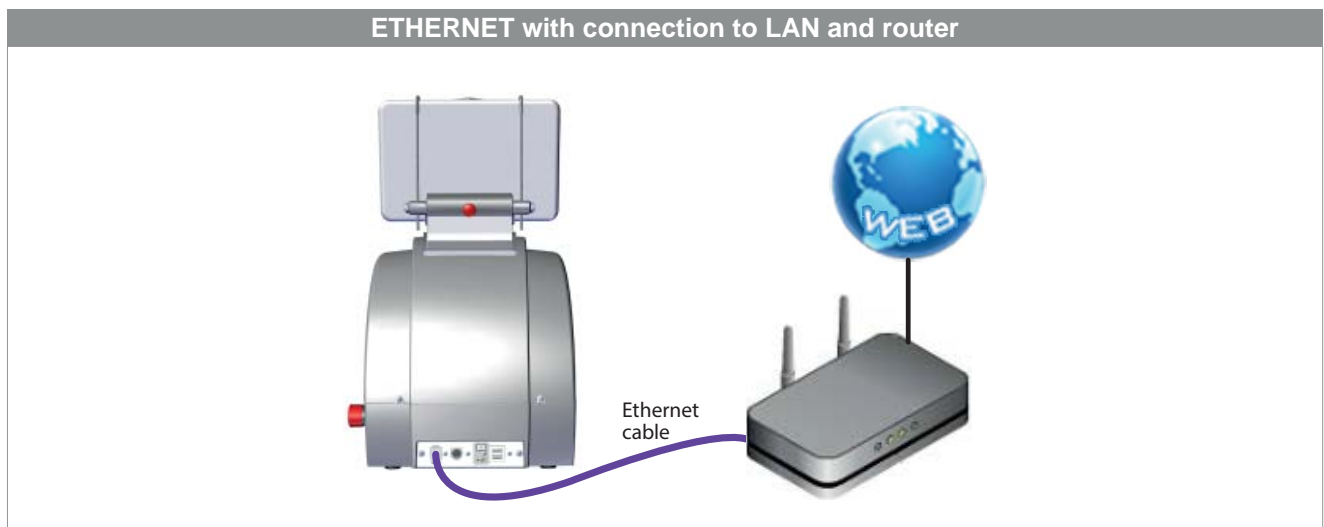

Fig. 10

6.3.3.c TETHERING USB mode

This method is used to connect the machine to a Tablet by means of a USB cable.
 Use the power cable provided with the Tablet.

Attention! This control is active and can be selected only if:

- the Tablet Wi-Fi network is disabled (OFF).
- the USB cable is connected to the Tablet and machine (Fig. 11).
- an Ethernet cable is not connected to the machine port.

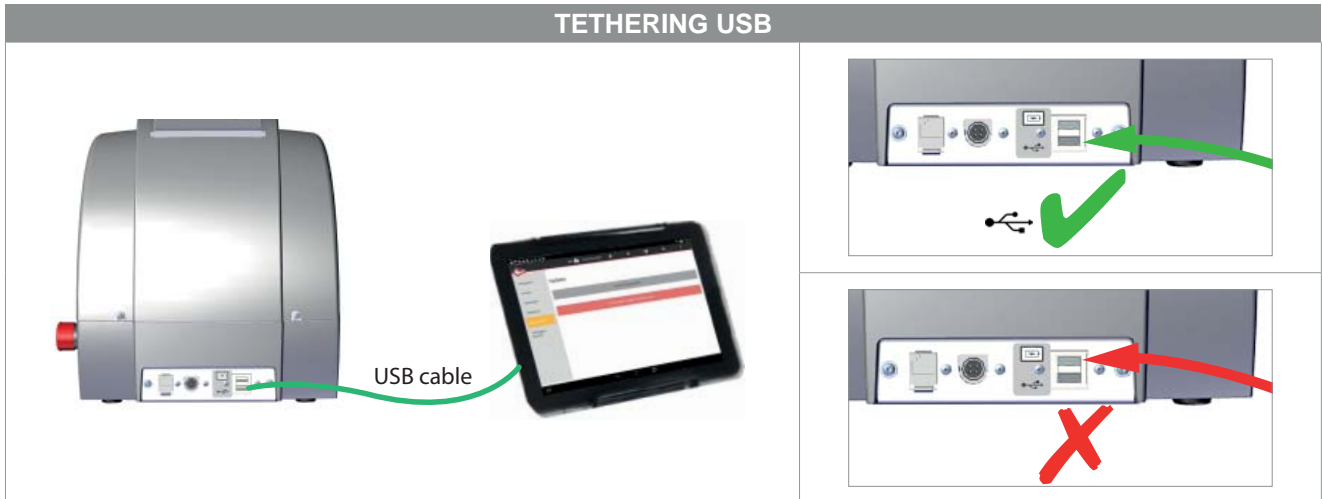
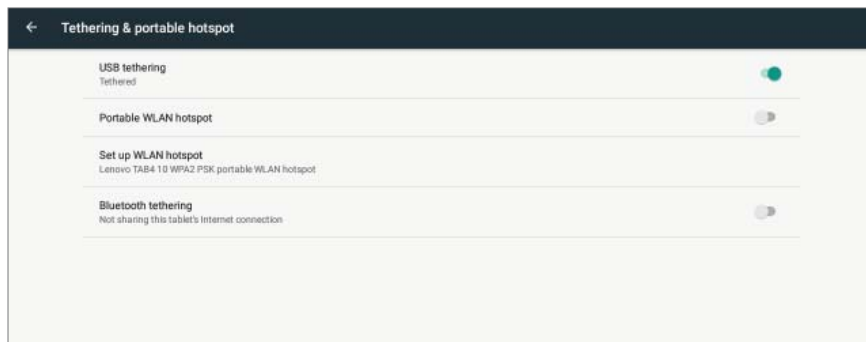
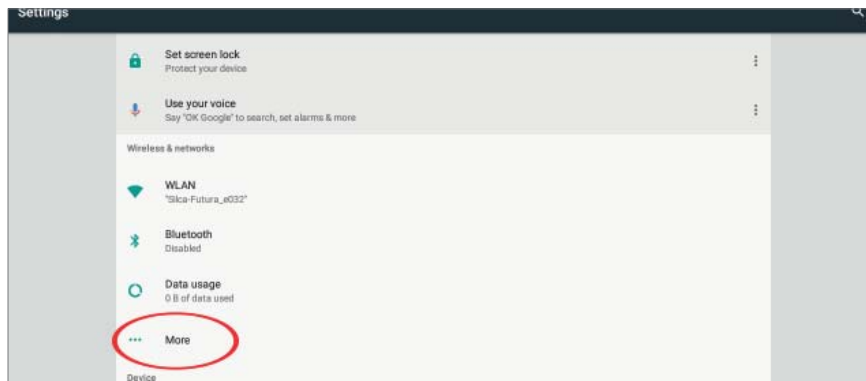

Fig. 11

- 1) Connect the USB cable to the machine and Tablet (Fig. 11 **Note: FUTURA ONE has one USB port only.**)
- 2) Access "Settings" ⚙️ on the Tablet.
- 3) Set "OFF" to disable the Wi-Fi.
- 4) In the Tablet "Settings" tap the "More..." icon and select the item "Tethering & Portable hotspot".



- 5) Tick "USB Tethering" or select "ON" to enable.

When this item is enabled a green light on the machine will flash for a few seconds. It may take 10-20 seconds for this to happen.

Start the Silca Futura APP and open the drop-down menu.
 Select "Connect to" to find the machine.

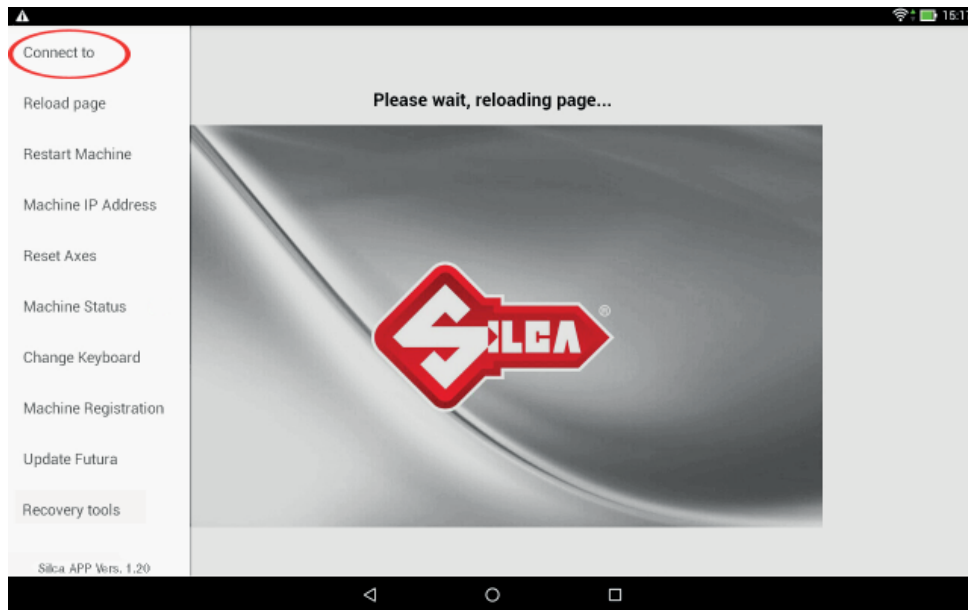

When the machine has been found, hit to select and establish connection.

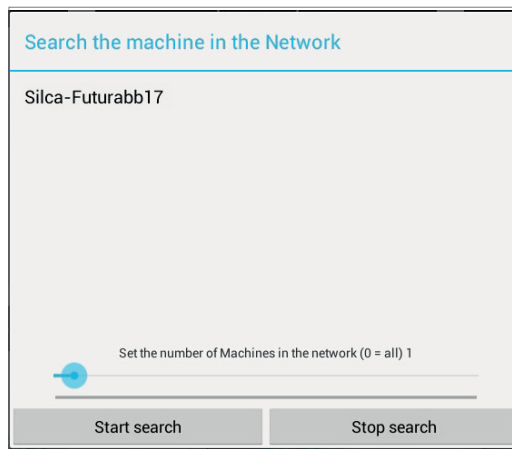

NOTE: if the Tablet and machine have been turned off, when turning on the USB connection must be made again, in the way described above, if you wish to work with the Tethering USB mode.

NOTE: when the machine-tablet connection has been made, if necessary you can re-boot the tablet Wi-Fi connection to connect to the internet.

6.3.3.d LOCAL NETWORK mode

This mode is useful to connect the tablet and machine, sharing the internet access provided by the router. If this is required we suggest in any case using the “Ethernet with connection to LAN” configuration, as described in Chapter 6.3.3.b as it performs better.



Fig. 12

To access this method of use, go to the Options > Settings menu, select “Network setting” and hit the LOCAL NETWORK mode icon.

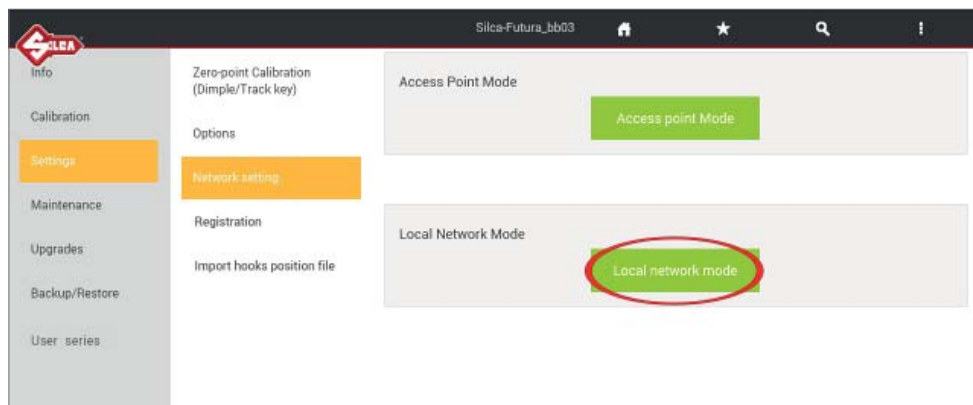

Perform the following operations to activate this method:

1) FUTURA CONNECTION TO A WI-FI ROUTER

Pick the network to which you want to connect by tapping the SSID field and then inserting the network's password.

Tap "Save" to reboot the machine in Local Network. The machine should initially reboot with a flashing white and blue light, to then end with two flashing blue lights that indicate the connection to the local network was successful.

If the inserted password was incorrect the machine would reboot in ACCESS POINT mode with an intermitted flashing blue light.

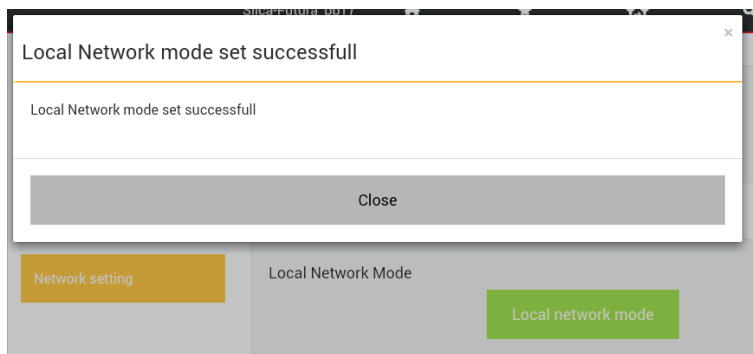
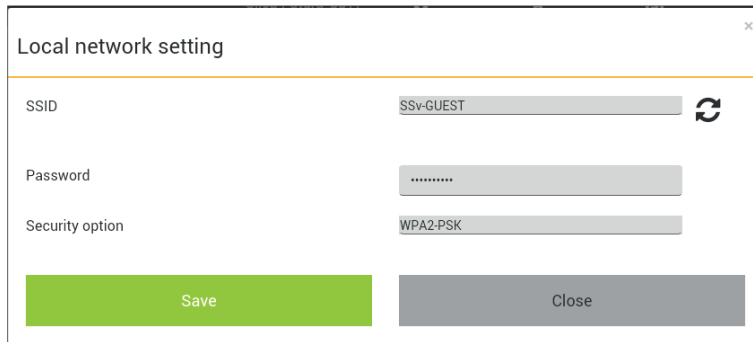
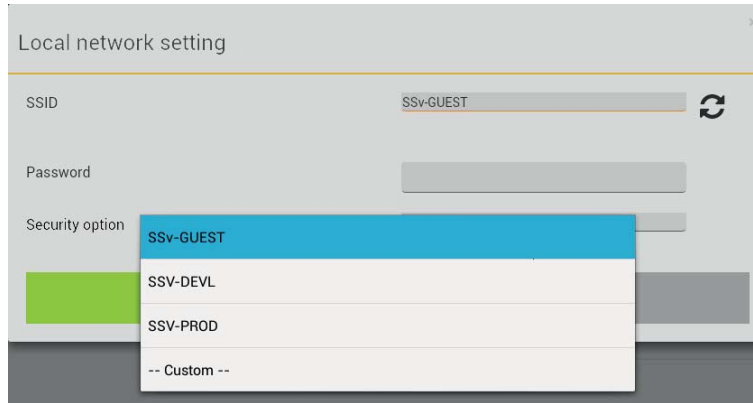

2) CONNECTING TABLET TO A WI-FI ROUTER

From the Tablet's "Settings" menu  tap on the desired network to connect.

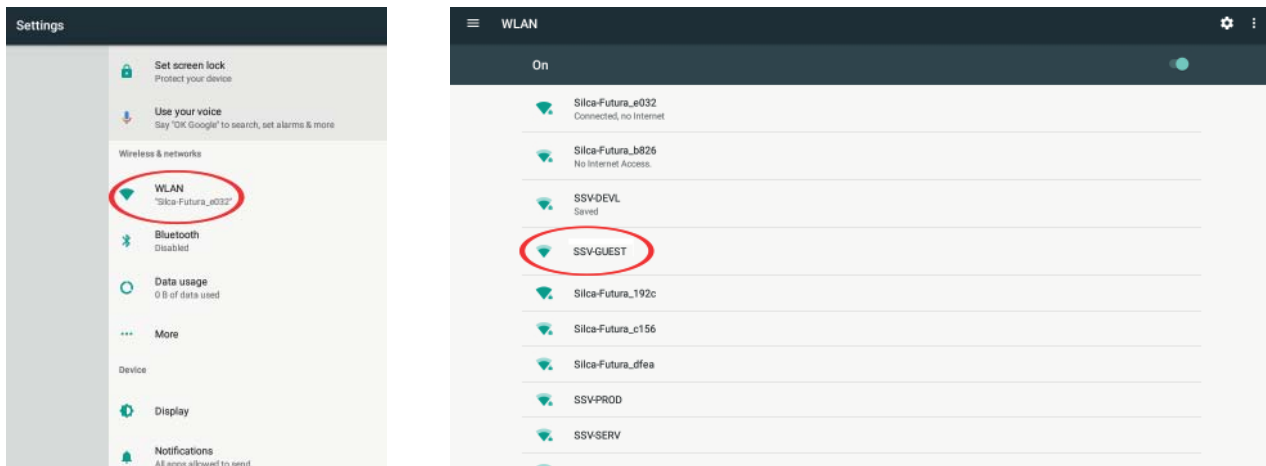

3) REBOOTING THE FUTURA'S APPS

Open the drop-down menu and select "Connect to".

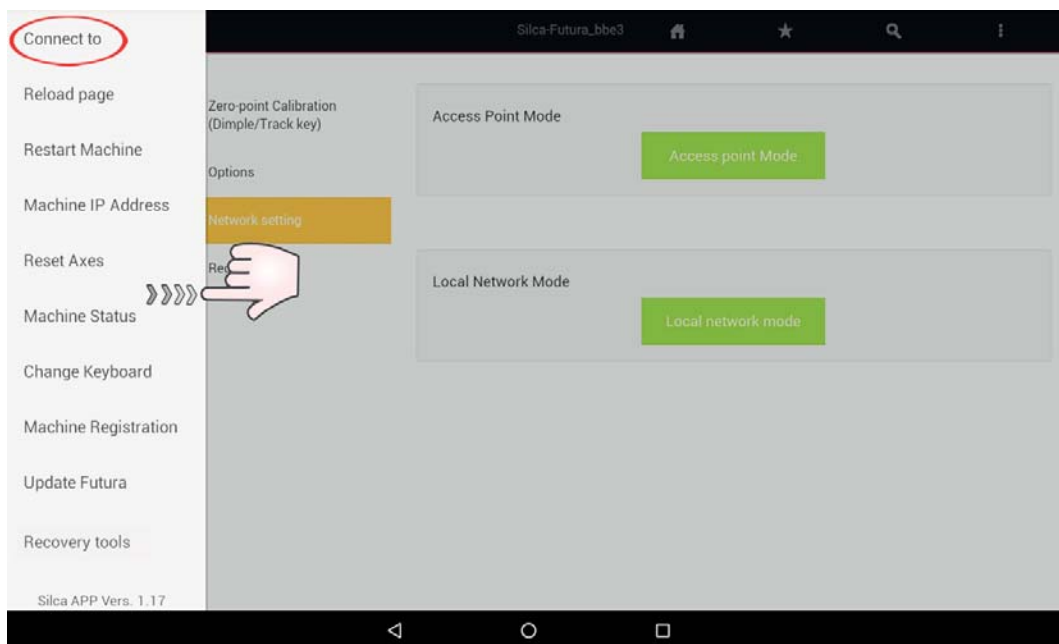

Tap on “Start Search” in the following window.

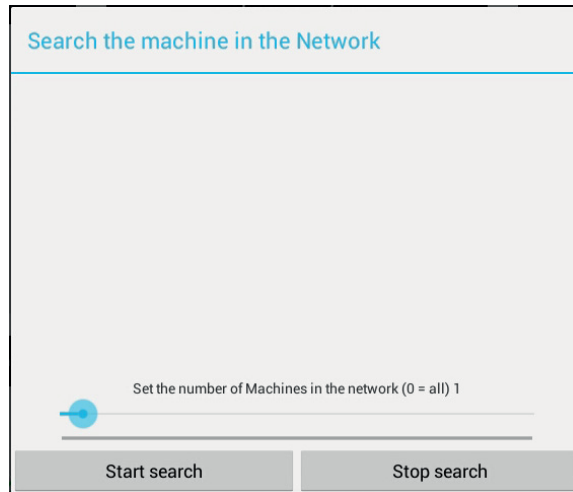

Tap on “Silca-Futura...” in the following window to obtain a connection between the Futura’s **APPS Silca.apk** and the machine.

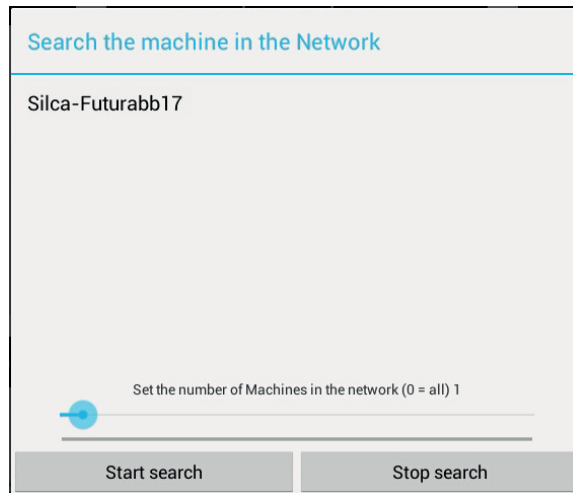

NOTE: the last mode setting will be automatically saved by the machine at each successive reboot; if the last set mode was LOCAL NETWORK and this mode is not recognized within a certain time frame the machine will automatically go to ACCESS POINT mode.

6.3.4 IMPORT HOOKS POSITION FILE

This function is used to import a CSV file containing a list of positions for hooks associated to the Silca keys stocked by a point of sale/key-cutting centre. The file is imported from a USB PEN inserted into the key-cutting machine USB port.

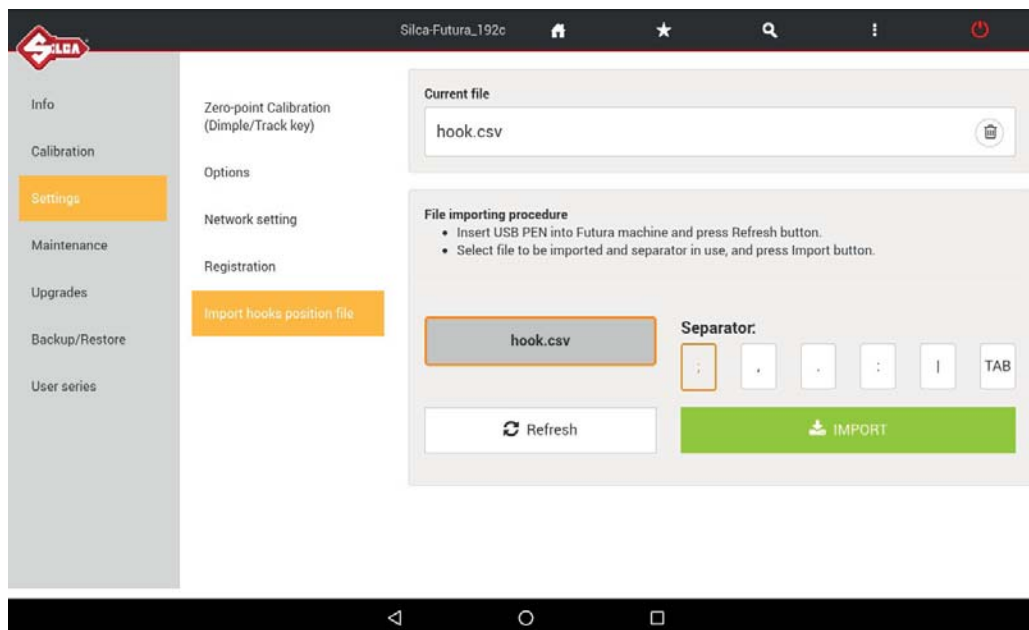

Example of list compilation (Silca key / Separator / Position):

- AGB5 ; A501**
- AGB8 ; A502**
- CS204 ; B600**
- CS206 ; B601**

The hook position is highlighted in the special field when carrying out a Search (Fig. 13) and Copy vehicle keys (Fig. 14) operation.

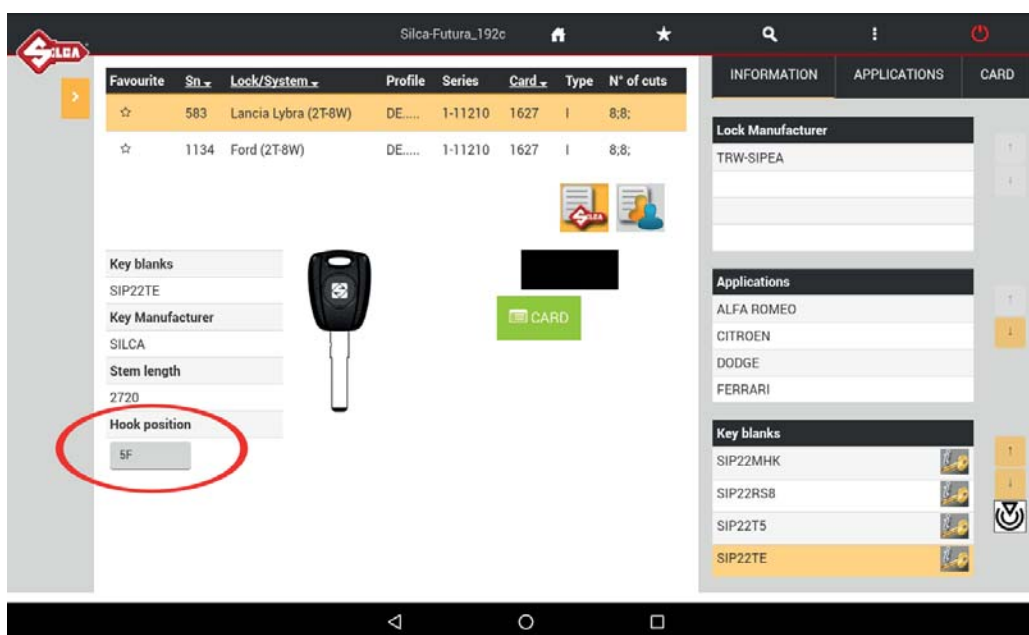

Fig. 13

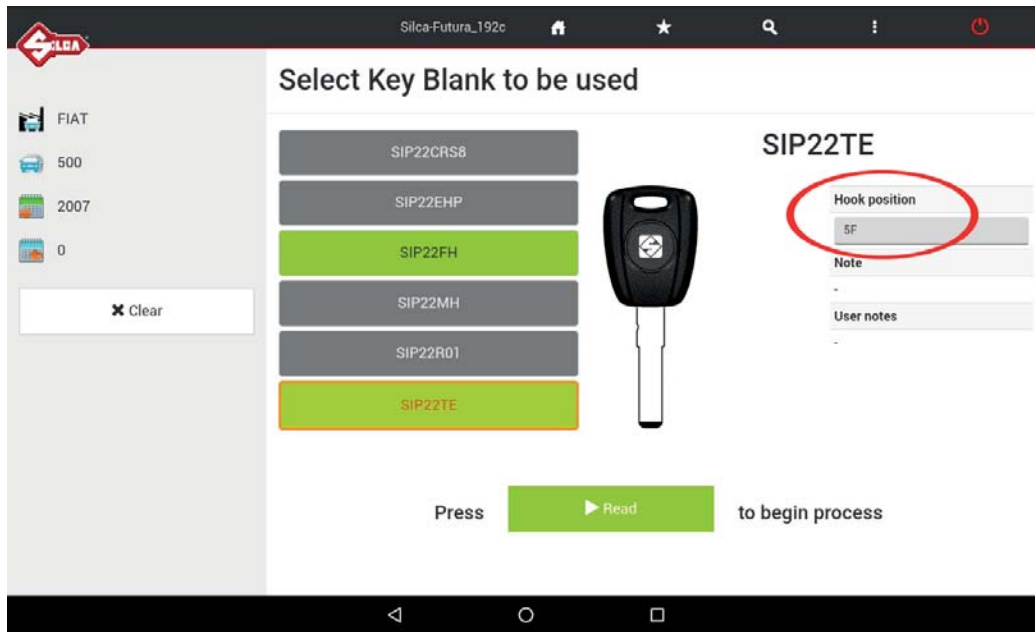

Fig. 14

6.4 MACHINE MAINTENANCE

• Digital Inputs

This function is used to test operation of the digital inputs on the electronic board to which they are connected: screen micro, gauge position sensor, electrical contact, etc.

To perform the test carry out the movement described for each item and check that the relative signal changes color from red to green.

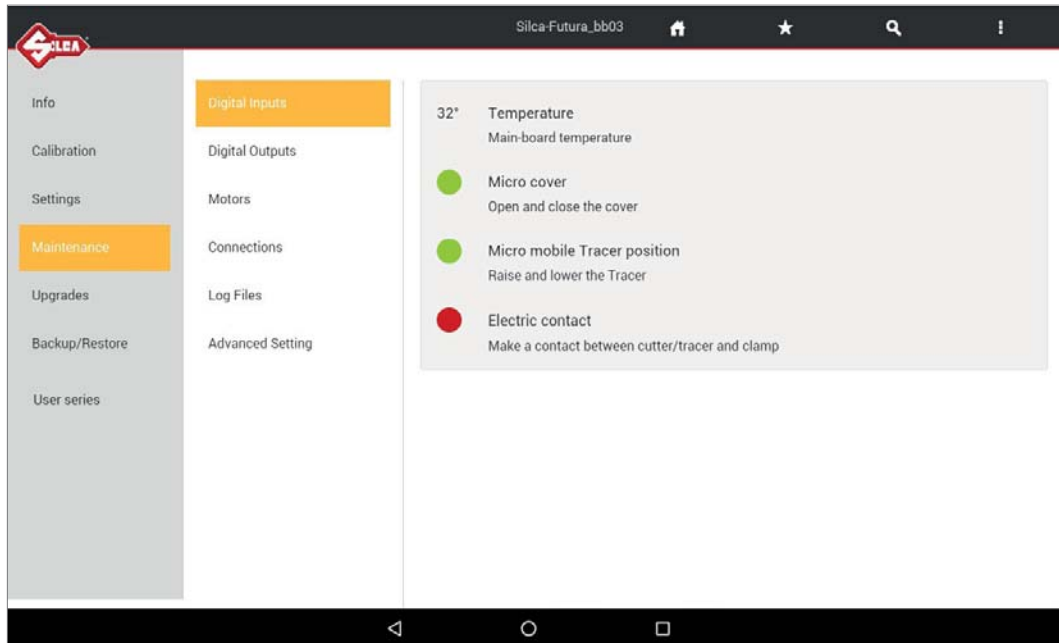

• Digital Outputs

This function is used to test operation of the digital outputs on the electronic board and relative devices connected to it. To perform the test tap ON on the screen.

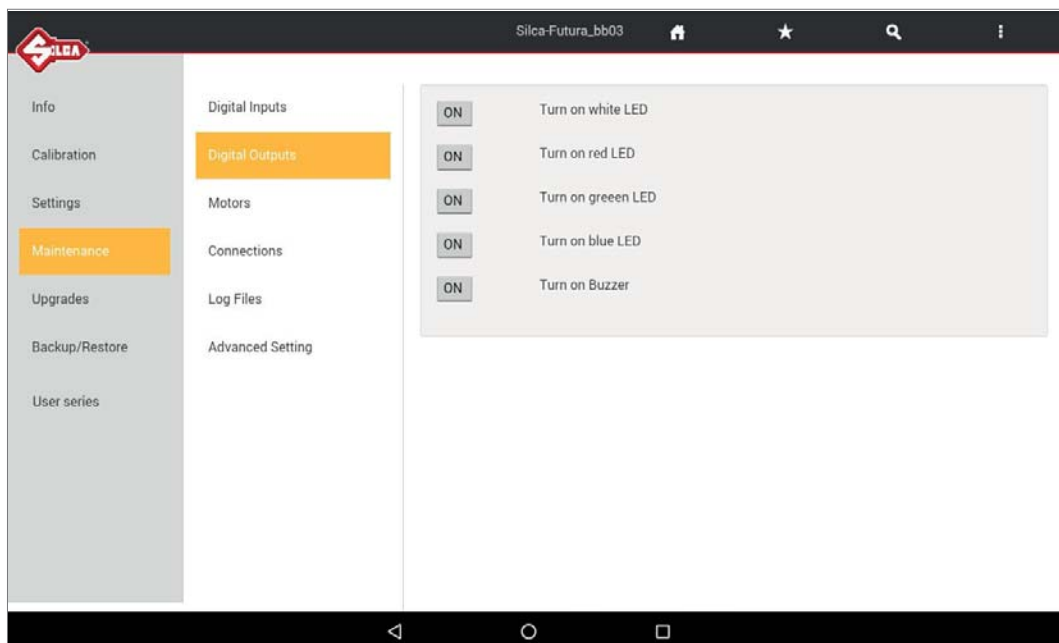

• **Motors**

This function is used to test operation of the 3 step motors for the X, Y and Z axes (at the moment the B axis is not used). To perform the test tap “+” for the axis involved.

Note: the carriage must not reach and hit the end of its run.

The Reset key homes the axes.

NOTE: tap “-” only when the value shown in the “Working position” field is positive.

Axis clearance sensor: the ring becomes green when activated.

• **Cutter motors**

To perform the test tap the button for the motor to be tested: check that the cutter turns for 5 seconds.

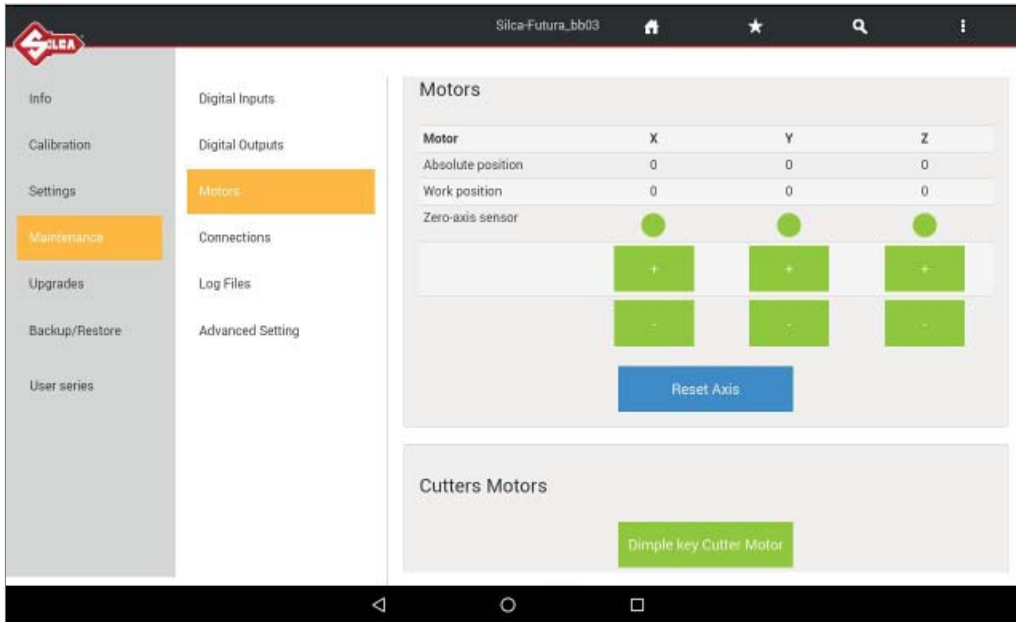

• **Connections**

This function shows all the machine connections that are available.

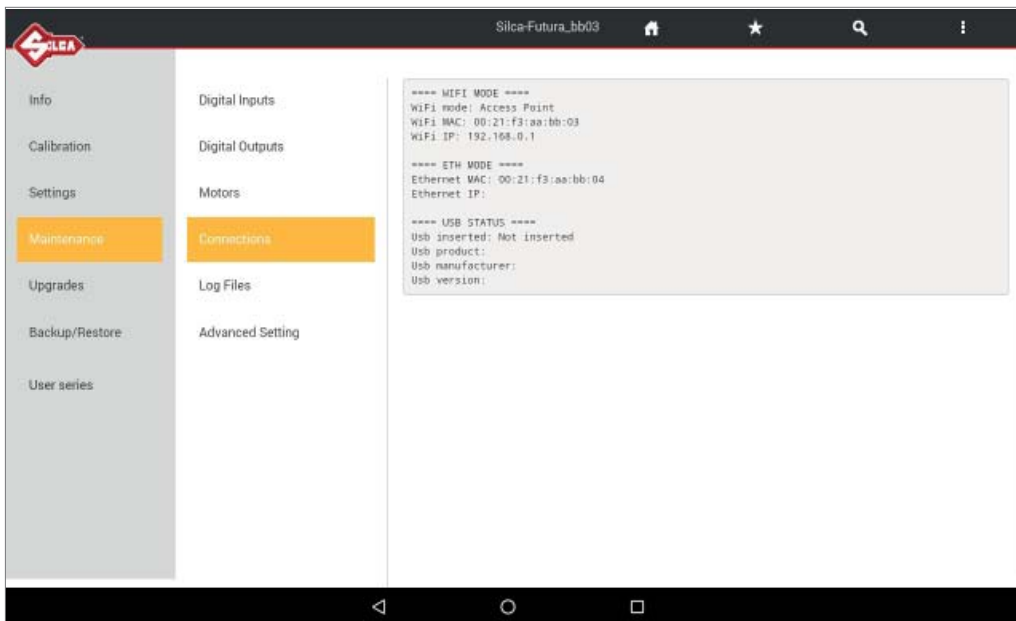

• **Log Files**

The Log file is requested by Silca when on board machine software anomalies are encountered. This function permits to create and save a log file:

- on a USB key connected to the machine's USB port (Fig. 15). **Note: FUTURA ONE has one USB port only.**
- or directly to Silca's Server (with the Futura machine connected to a local network) Wi-Fi or LAN cable connection).

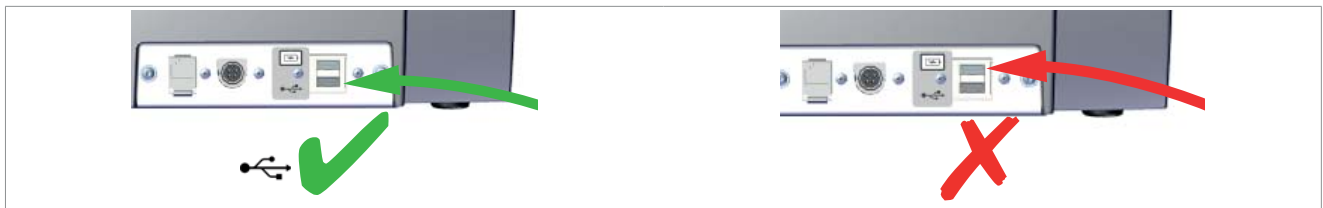
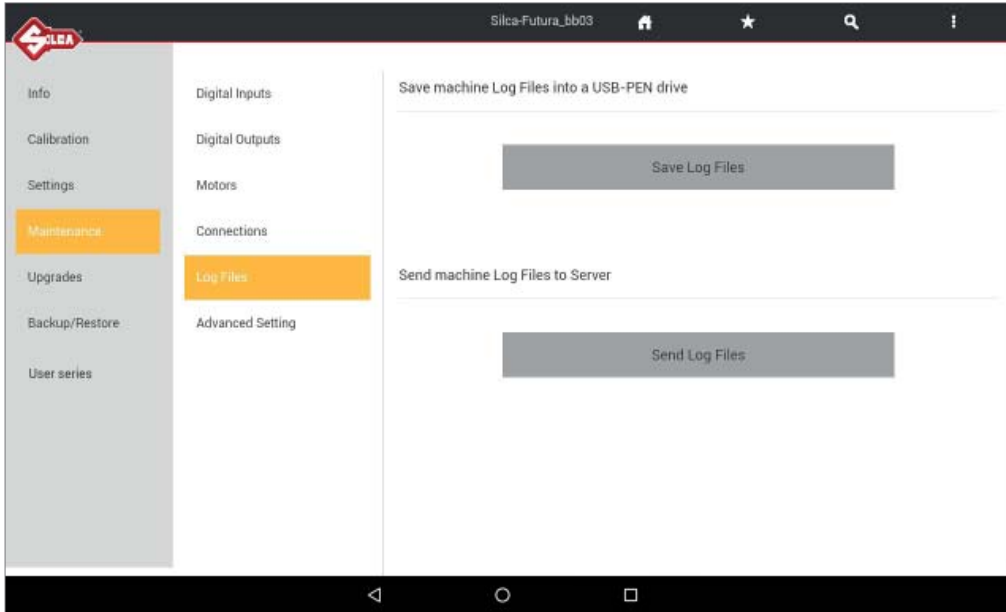
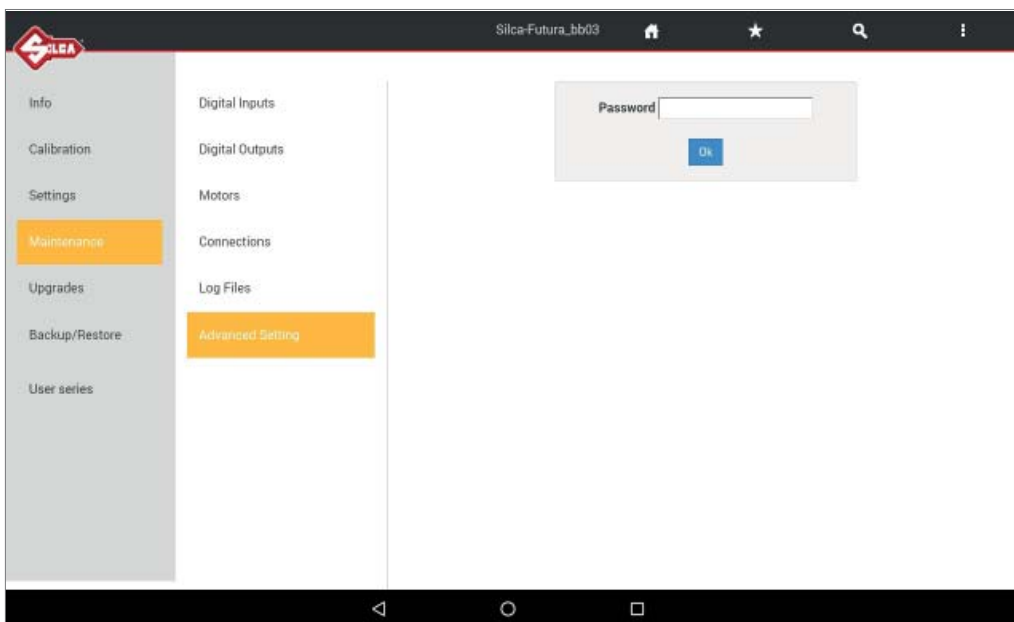

Fig. 15 - Futura Pro One

• **Advanced Setting**

Function for Silca internal use.



7 MACHINE UPDATE AND REGISTRATION

7.1 MACHINE REGISTRATION

To download the machine software updates you must be registered on the SILCA WEB FUTURA server. **This operation is required only on first access.**

After cutting at least 50 keys you are required to register the machine (only if not yet done) on the Silca FUTURA web server.

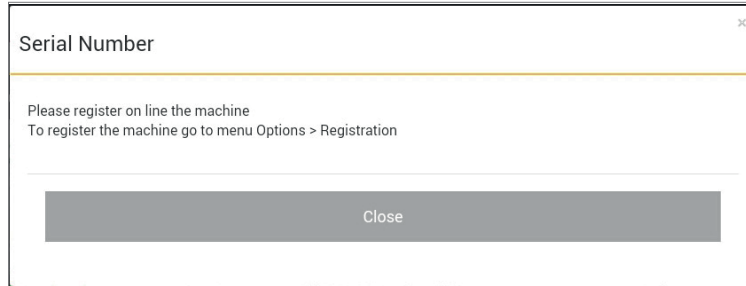

- If the machine is not registered now, the same message will appear every time Futura One / Futura Pro One is started.
- If the machine is not registered it will not be possible to download software updates.

There are 4 ways to register:

Method 1: Futura One / Futura Pro One machine with access to the internet

Method 2: Futura One / Futura Pro One tablet with access to the internet

Method 3: Using the Silca Remote Service (SRS) program

Method 4: Using a browser on a PC/tablet connected to the internet

Method 1

Futura One / Futura Pro One with access to the Internet

- Start the FUTURA program; tap the icon OPTIONS -> Settings -> Registration
- Enter the data into the fields shown (those with * are required) and then tap Register and wait for a message communicating that the machine has been registered. Tap Close.

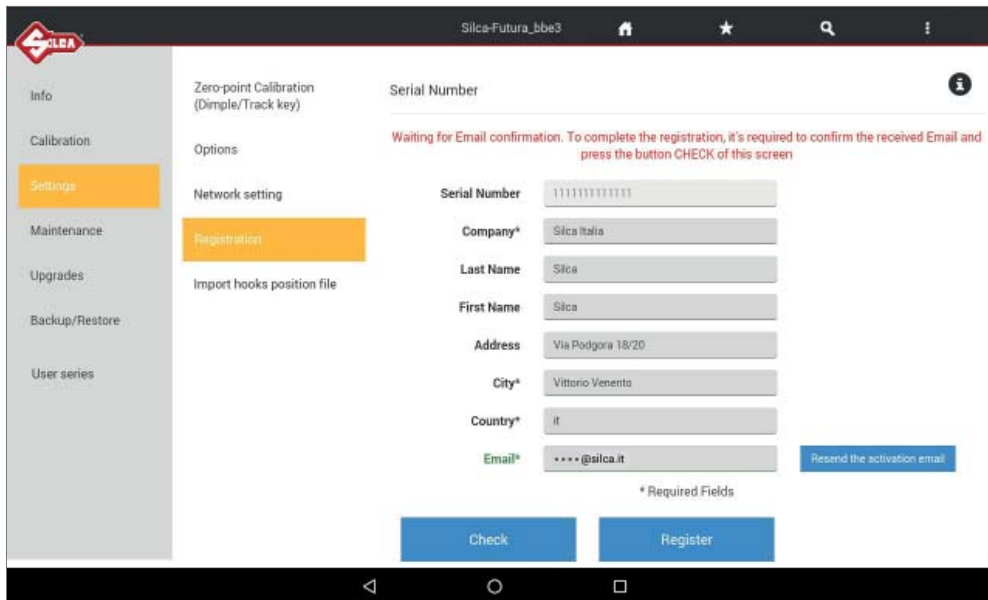

NOTE: tap to view the registration method for Futura machines.

A message confirming registration will arrive at the address given.
 Use your mail program to open the e-mail from Silca and click on "Validating email".

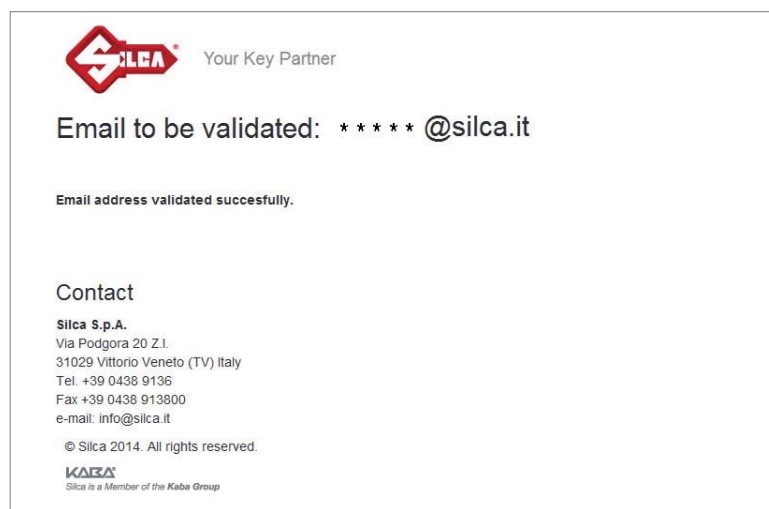

- At the end, tap "Close" and then "Check" to conclude the registration procedure on the Tablet.

Method 2

Futura One / Futura Pro One tablet with access to the internet

NOTE: the Tablet must be taken where there is a Wi-Fi connection with internet access.

Connect a tablet to your local Wi-Fi network and connect to the internet to start the Silca FUTURA app. Scroll from left to right to open the drop-down menu, as shown below.

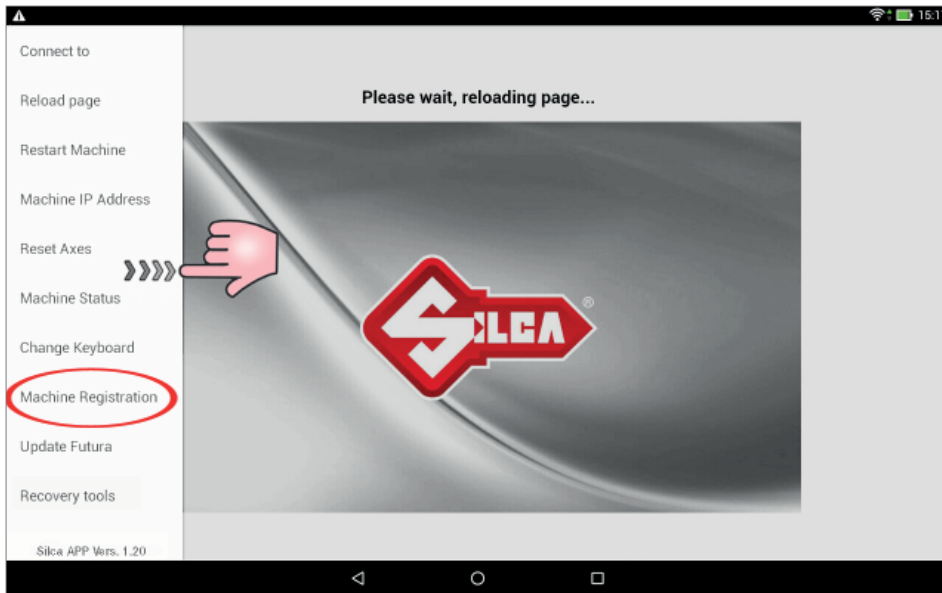

Tap “Machine Registration” to find the serial number.

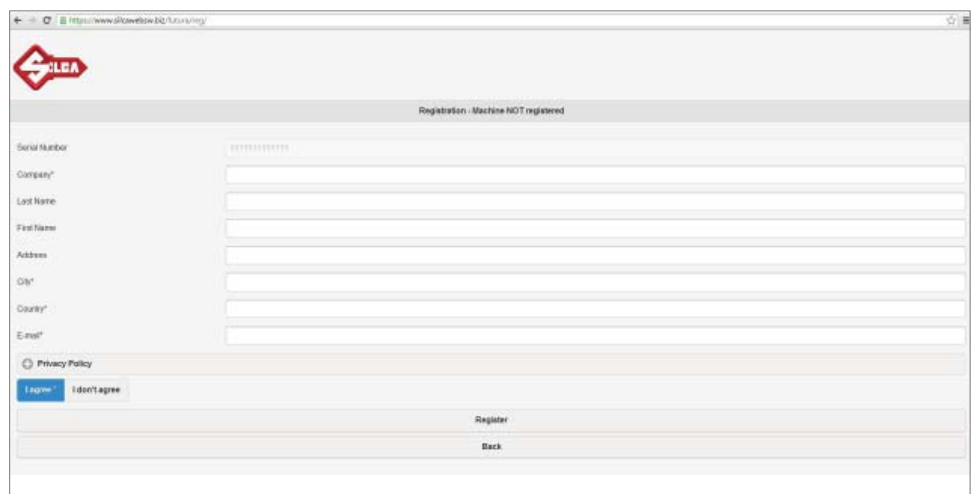
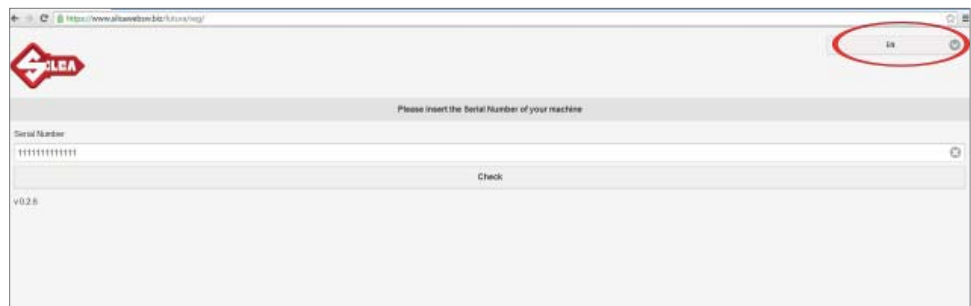

- If the serial number is not read, digit its thirteen numerical characters and press “Check”.
- Enter the data into the fields shown (those with * are required) then tap Register.

- A message confirming registration will arrive at the address given. Use your mail program to open the e-mail from Silca and click on **“Validating email”**.



- Go back to the Futura One / Futura Pro One machine and re-connect in Access Point mode.

NOTE: when the machine is updated for the first time registration data will be transmitted by the Futura WEB server to the machine.

Method 3

Using the Silca Remote Service (SRS) program

FUTURA machine and tablet connected in ACCESS POINT mode

Install the “**Silca Remote Service**” program on your PC. The program can be downloaded from the Silca website www.silca.biz, by selecting the Products menu -> Silca Key Programs -> SKP Modules -> Silca Remote Service.

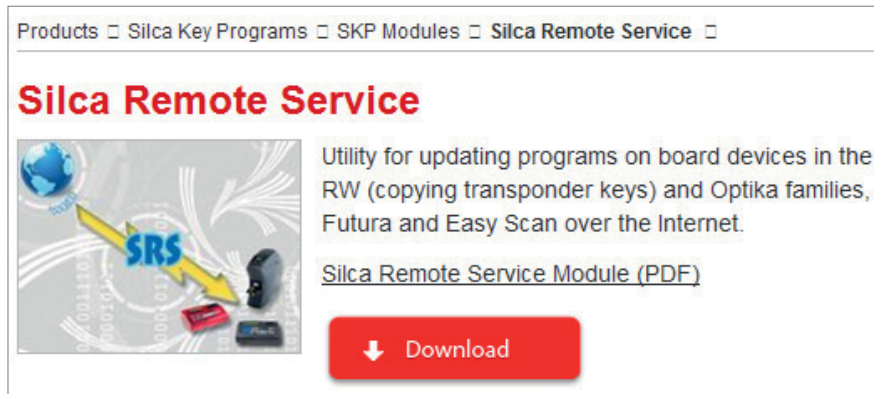

- Start the program and select the Futura One / Futura Pro One machine model, select the “Next” button and then “Register”: a dedicated web page will appear.
- If the machine has not already been registered, enter the data in the relevant fields (fields marked * are required) and then tap “Register”.
- A message will be sent to the given email address to confirm registration. Use your mail program to open the email from Silca and click on “**Validating email**”.

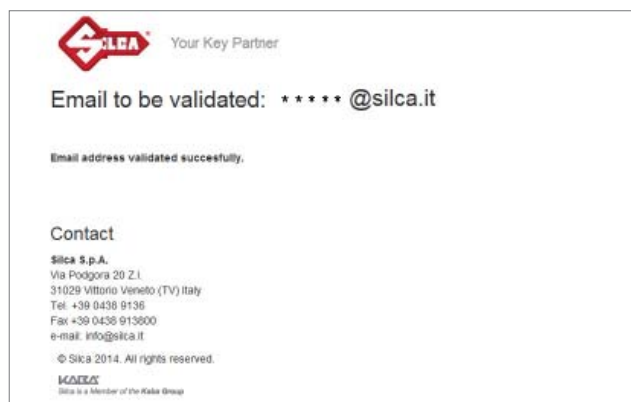
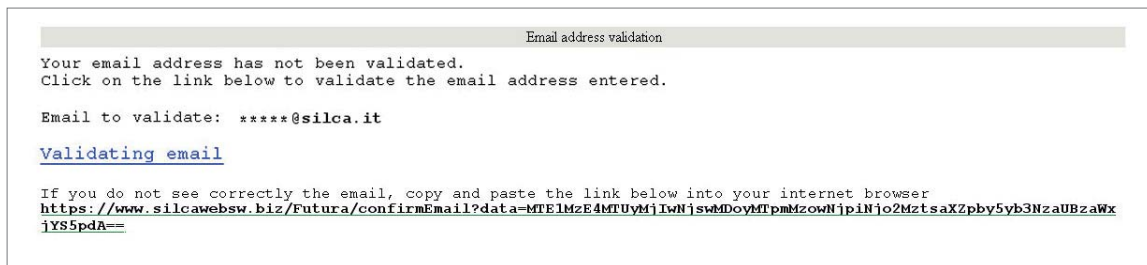

The machine is now registered.

7.2 MACHINE SOFTWARE UPDATE

Silca periodically releases Software and Data Updates for the machine. To check for new updates use one of the connection methods available.

ATTENTION: do not insert a USB modem sticks for the transfer of data in the machine USB port.

NOTE: before starting, check that the machine is registered (shown on the Machine Registration screen - on the Tablet scroll from left to right to open the drop-down menu).

Futura One / Futura Pro One can be updated in one of the following ways:

- 1) Update by TABLET
- 2) Update by USB PEN DRIVE
- 3) Update through LOCAL NETWORK
- 4) Update by SRS (Silca Remote Service) program

7.2.1 Update by TABLET



Fig. 16

ATTENTION: make sure there is no USB PEN in the Futura One / Futura Pro One machine USB port during updating.

- 1) Take the tablet to a place with a Wi-Fi network and internet connection and connect.
- 2) Start the Silca Futura APP and follow the instructions on the screen:
 - On the Tablet scroll from left to right to open the drop-down menu.
 - Tap “Machine registration” (Fig. 17).
 - Enter the machine serial number (13 digits) and then tap “Check”.

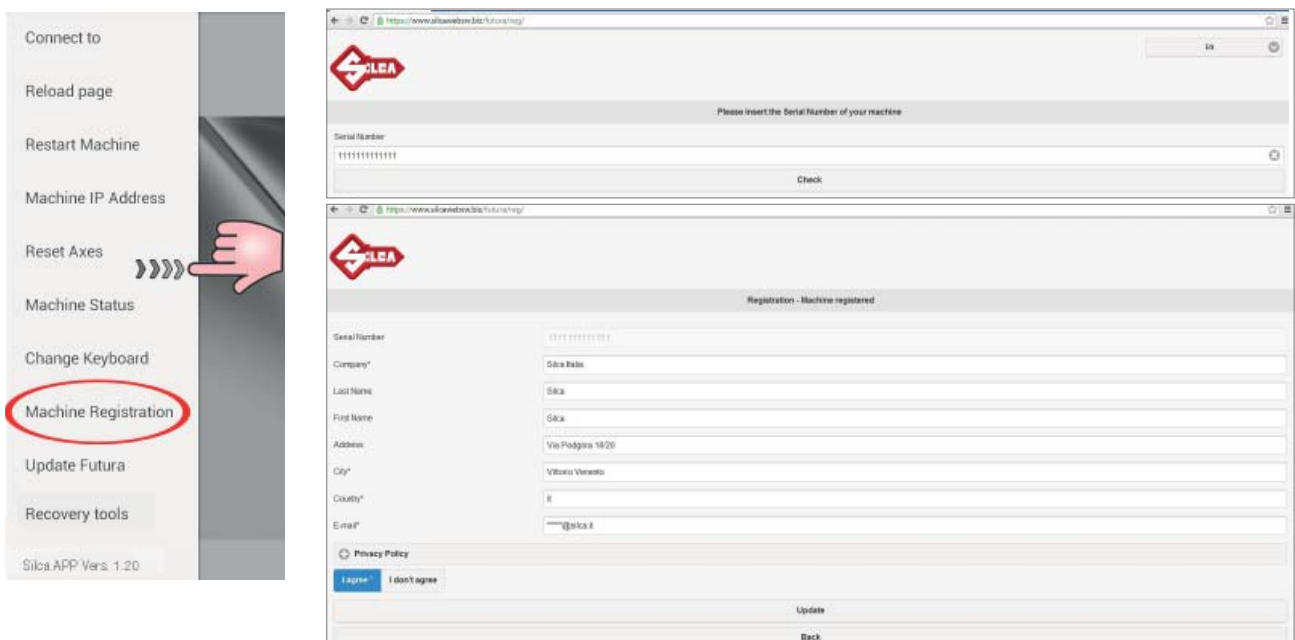

Fig. 17

- On the Tablet scroll from left to right to open the drop-down menu
- Tap “Machine update”; the following screen will appear:

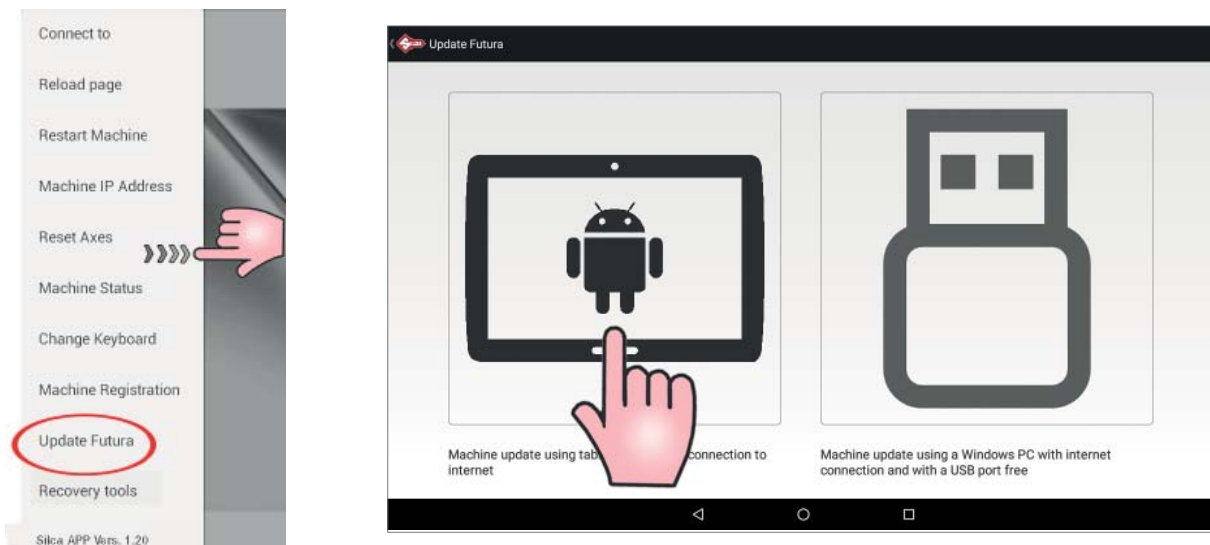

Fig. 18

- Click on the tablet image (Fig. 18) and follow the guided procedure (if the tablet is not connected to a Wi-Fi network you will see a screen from which a Wi-Fi network can be selected).
- When the new update has been downloaded you will be asked to re-start the machine so that the update will be applied automatically.
- Press the “Re-start machine” button and wait a few minutes. The tablet will automatically connect to Futura One / Futura Pro One.

7.2.2 Update by USB PEN

This update procedure is used to update the Futura One / Futura Pro One machine using a PC connected to the internet and a USB PEN.

- 1) Select “Machine update” from the drop-down menu and tap the USB PEN image (Fig. 19). Insert the USB PEN DRIVE into the machine and follow the instructions on the screen.

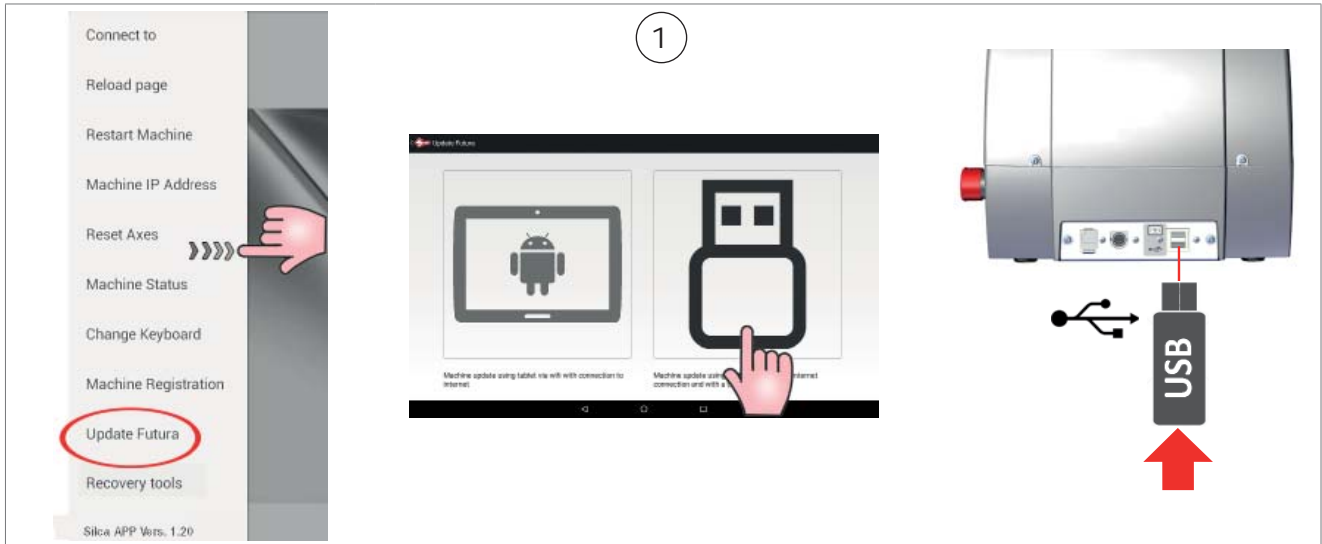

Fig. 19

- 2) Insert the USB PEN DRIVE into a PC connected to the internet (Fig. 20).
 - Open the USB PEN DRIVE, click on the file “FuturaUpgrade.exe” and wait for the “operation successful” message to appear on the screen.
 - Remove the USB PEN DRIVE from the PC (safe hardware removal).

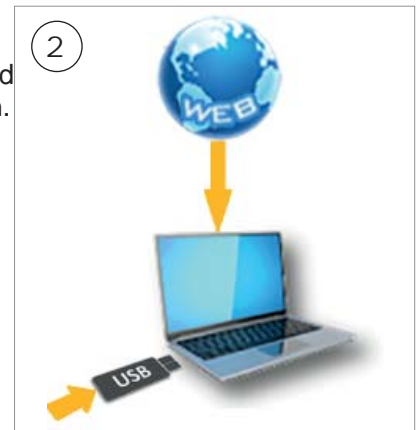

Fig. 20

Insert the USB PEN DRIVE into the special port (Fig. 21). **Note: FUTURA ONE has one USB port only.**

Follow the instructions on the screen: tap the “RE-START FUTURA” button to re-start the machine.

- Wait a few minutes until the white light flashes regularly.
- Remove the USB PEN DRIVE from the machine (without turning it off). Wait for Futura One / Futura Pro One to re-start (regularly flashing blue light).
- Start the FUTURA APP from your tablet.

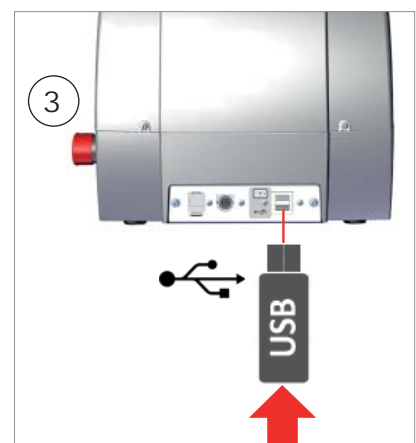

Fig. 21

7.2.3 Update with LOCAL NETWORK connected to the internet



Fig. 22

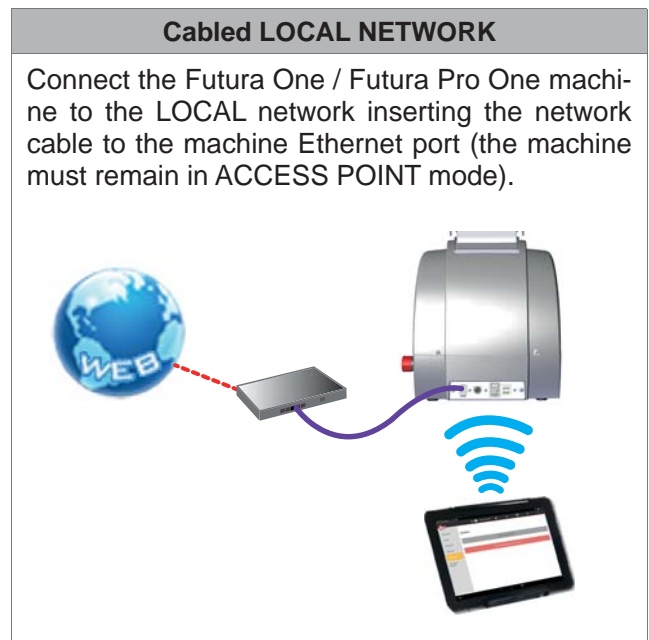

Fig. 23

ATTENTION: make sure there is no USB PEN in the Futura One / Futura Pro One machine USB port during updating.

To upgrade the machines software in manual mode, follow the steps indicated below.

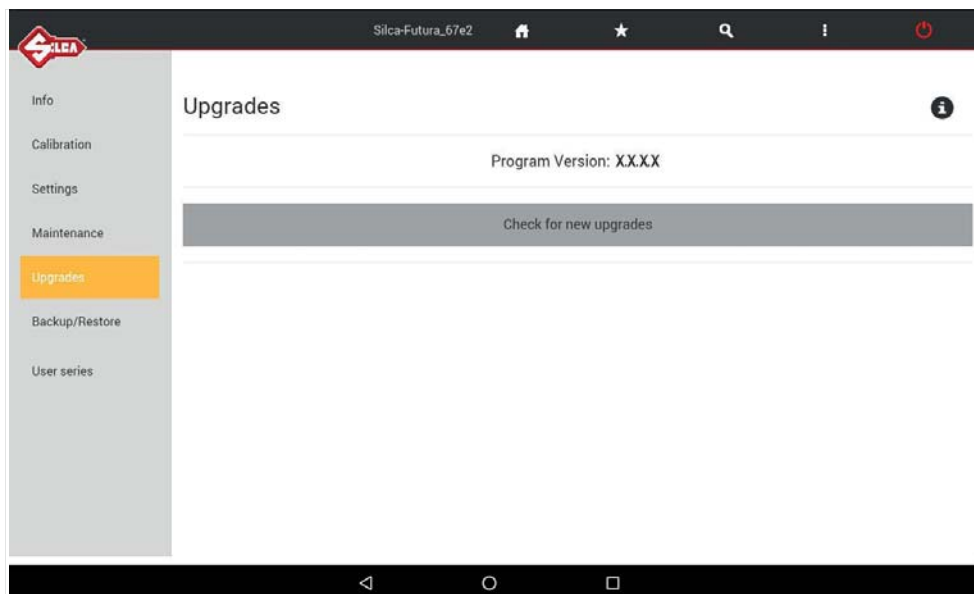

Fig. 24

NOTE: tap ⓘ to view machine update methods.

- Tap on “Check for Updates” to get a list of what will be downloaded with the update.

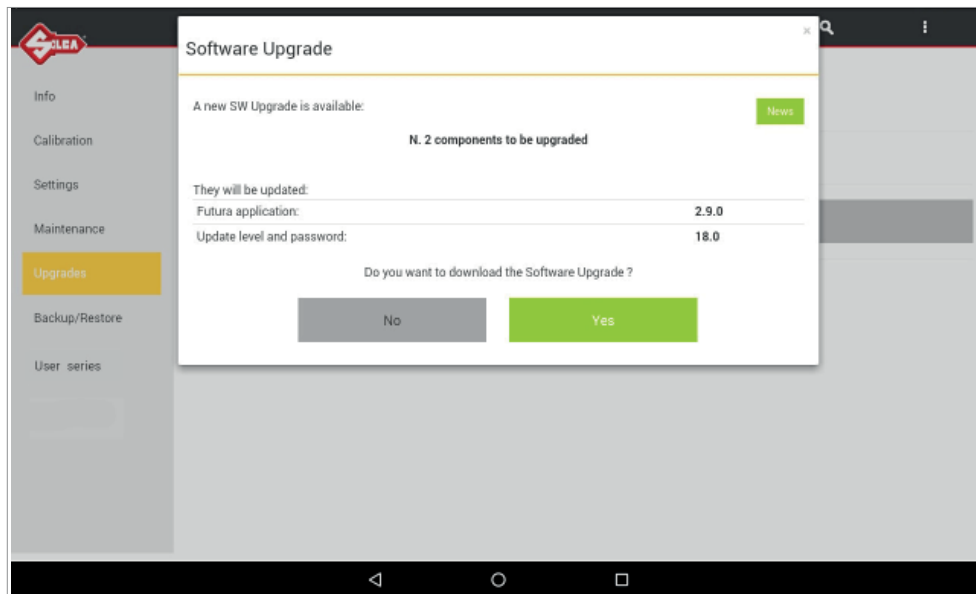

Fig. 25

- Tap “News” to see information about the update to be installed on the machine.
- Tap on “Yes” to start downloading.
- When download is over, you will be asked to restart the machine (procedure run by the software). Follow the on-screen instructions.

7.2.4 Update with SRS Program (Silca Remote Service)



Fig. 26

Install the “Silca Remote Service” program on your PC. The program can be downloaded from the Silca website www.silca.biz, by selecting the Products menu -> Silca Key Programs -> SKP Modules -> Silca Remote Service



The machine can be updated in the following ways:

Method 1 (QUICK update)

QUICK update saves time as it downloads only the files needed.

ATTENTION: you need a blank FAT32/NTFS format USB PEN.

- Fit a blank format FAT32/NTFS USB PEN into the Futura One / Futura Pro One machine and open the machine software; go to the Diagnostics menu -> Log File and press “Save log file” on the USB PEN.
- Fit the USB PEN into the PC on which the SRS program is installed, go to the SRS program screen regarding **QUICK update** preparation and wait for the update file to be saved on the machine. If the machine is not registered you will be required to register using the special website page.
- Ensure that the Futura One / Futura Pro One machine is off (red push button) and that the FUTURA APP on the Tablet is closed.
- Fit the USB PEN into the machine USB port (on the rear - Fig. 15, page 65).
- Start the Futura One / Futura Pro One machine and wait a few minutes until the white light flashes regularly. Remove the USB PEN (without turning off the machine). Wait for Futura One / Futura Pro One to re-boot (blue light flashing regularly). Start the Futura APP from your Tablet.

ATTENTION: do not unplug or turn off Futura One / Futura Pro One during updating.

Method 2 (TOTAL update)

TOTAL update will download all the files on the machine

Start the program  and select the Futura One / Futura Pro One machine.

ATTENTION: you need a blank FAT32/NTFS format USB PEN.

- Enter the Futura One / Futura Pro One machine serial number into the SRS program screen regarding update preparation and then fit a USB PEN into the PC. Wait for the TOTAL update file to be saved on the USB PEN. If the machine is not registered you will be required to register using the special website page.
- Ensure that the machine is off (red push button) and that the FUTURA APP on your Tablet is closed.
- Fit the USB PEN into the machine USB port (on the rear - Fig. 15, page 65).
- Start the Futura One / Futura Pro One machine and wait a few minutes until the white light flashes regularly. Remove the USB PEN (without turning off the machine). Wait for Futura One / Futura Pro One to re-boot (blue light flashing regularly). Start the Futura APP from your Tablet.

ATTENTION: do not unplug or turn off Futura One / Futura Pro One during updating.

7.3 APP UPDATE (Silca.apk e SilcaKeyboard.apk)

After you updated the Futura One / Futura Pro One machine’s software, when the program starts up, you may see the following screen indicating that a new version of the **Silca.apk** or **SilcaKeyboard.apk** is available.

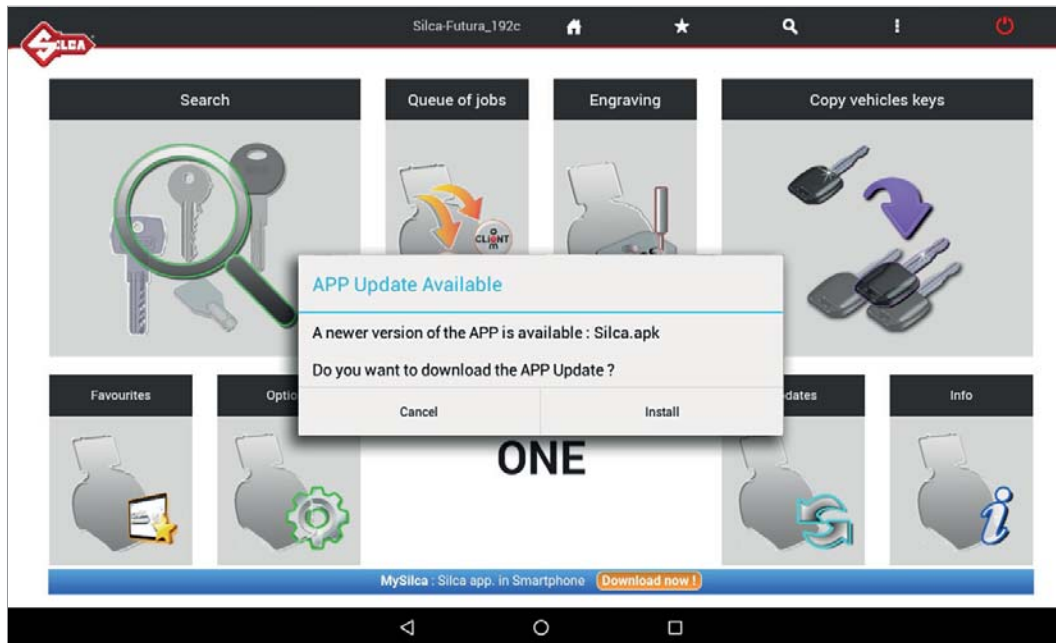

Fig. 27

Tap on “Install” and proceed with updating the APP.

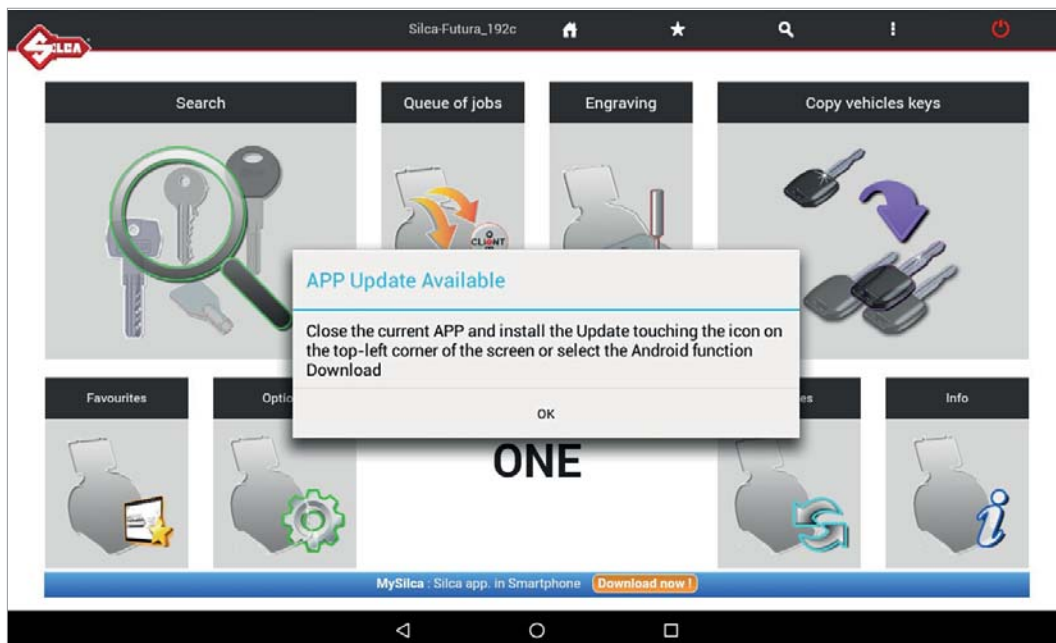



Fig. 28

Close the application that is opened by tapping on  and dragging the Futura APP (see Fig. 29).



Fig. 29

- 1) Tap the center bottom “Open all APPS screen” icon 
- 2) Enter “File Manager” and tap on “Downloads”.

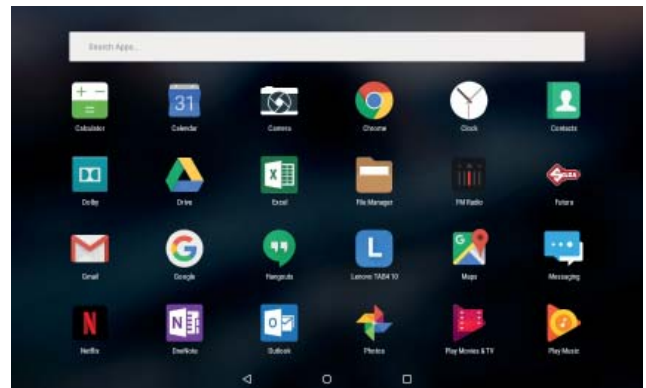
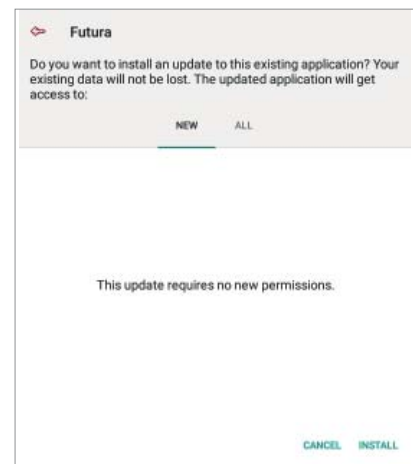
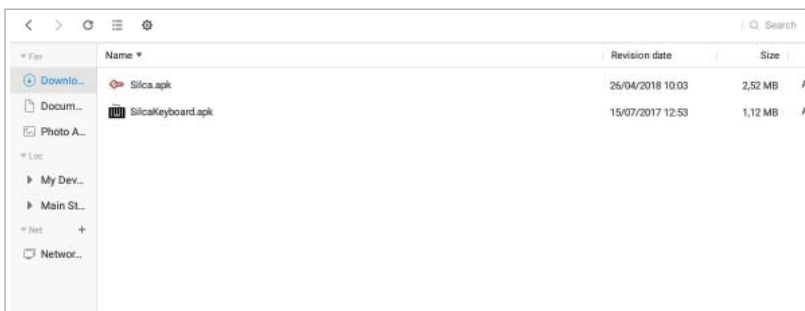

Fig. 30



- 3) Select **Silca.apk** and tap on “Install”.
- 4) Wait for the update to finish.
- 5) Do the same for upgrading the **SilcaKeyboard.apk**.

8 BACKUP / RECOVERY

This function permits to create and save a backup (backup User database) file in a USB PEN that can be connected the machine's USB port (Fig. 15, page 65).

Also provided is the recovery (Restore User database) function always using the USB PEN with the last file that was saved on it.

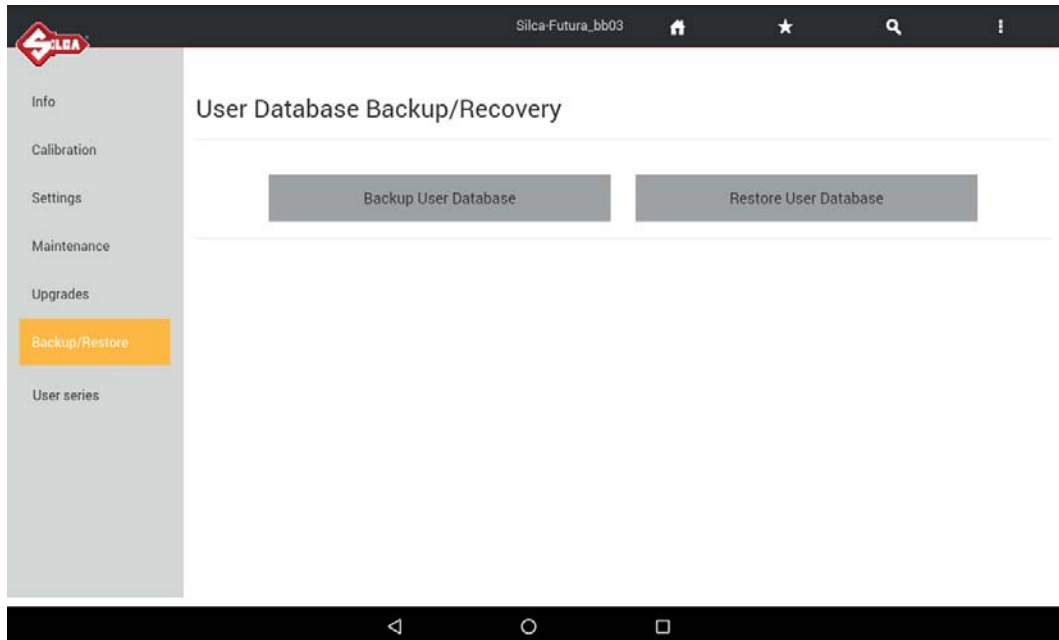

9 USER SERIES

Function accessible from “Options => User Series”.

This function is available to the user to import a code table in XML-Keso, CSV, TXT format, associating it to a data card and thereby creating a new user series.

- Use a USB-PEN, FAT32/NTFS format, and copy onto it the file (or files) with the table to be imported. **Note: the file must not be in a folder.**
- Insert the USB-PEN into the Futura One / Futura Pro One USB port.

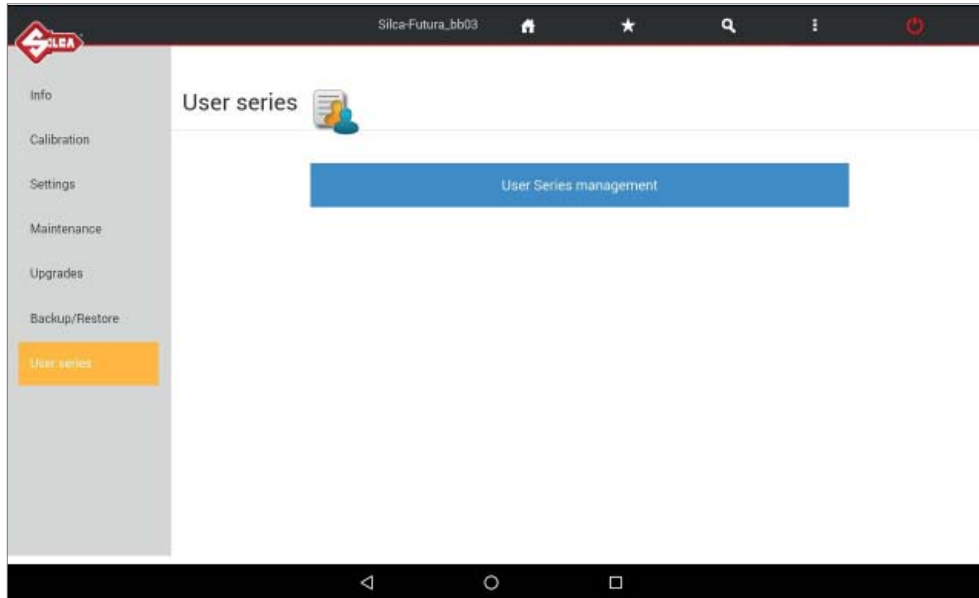

To create the user series, tap “User Series Management”.

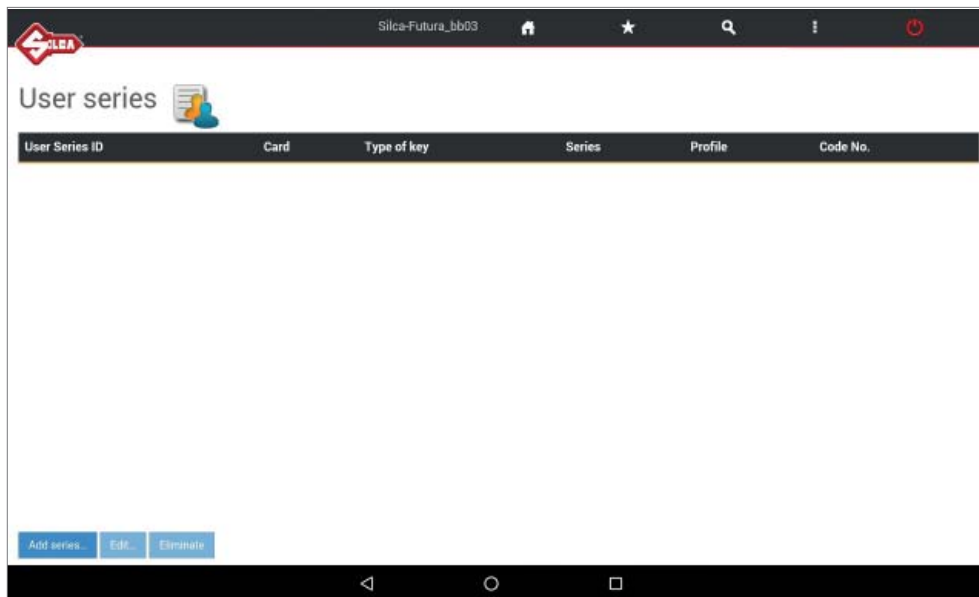

Tap “Add Series” to import the new file.

When the User Series exists and is selected/highlighted you can:

- tap the “Edit” key to vary certain parameters associated to the series.
- tap the “Eliminate” key to erase the selected series.

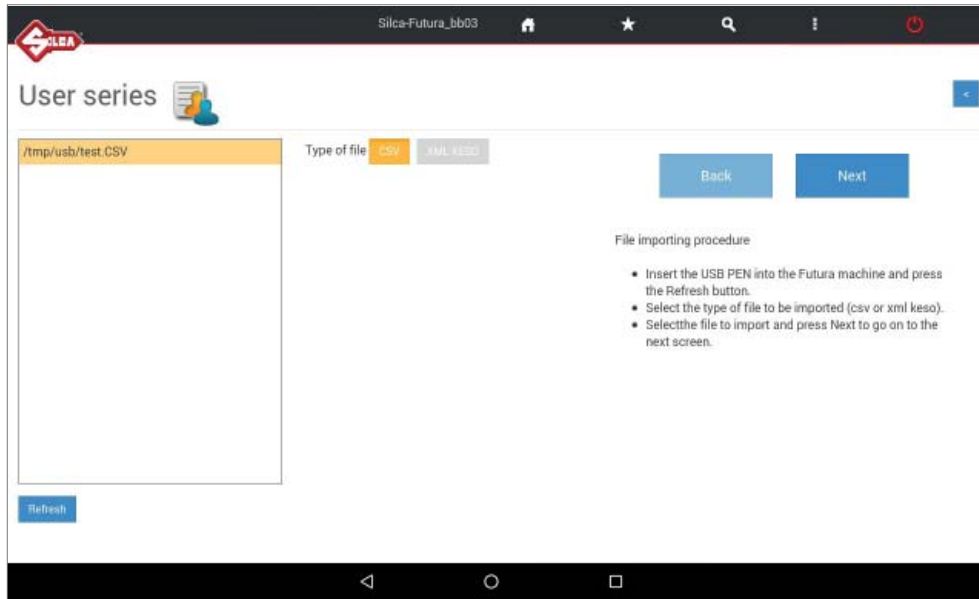

- Follow the instructions on the Tablet page. During guided import you will be required to enter or select certain parameters to associate to the new series (e.g. Data card number, Profile, Series, Makes, Applications and Key blank).
- Tap "Next" to continue.

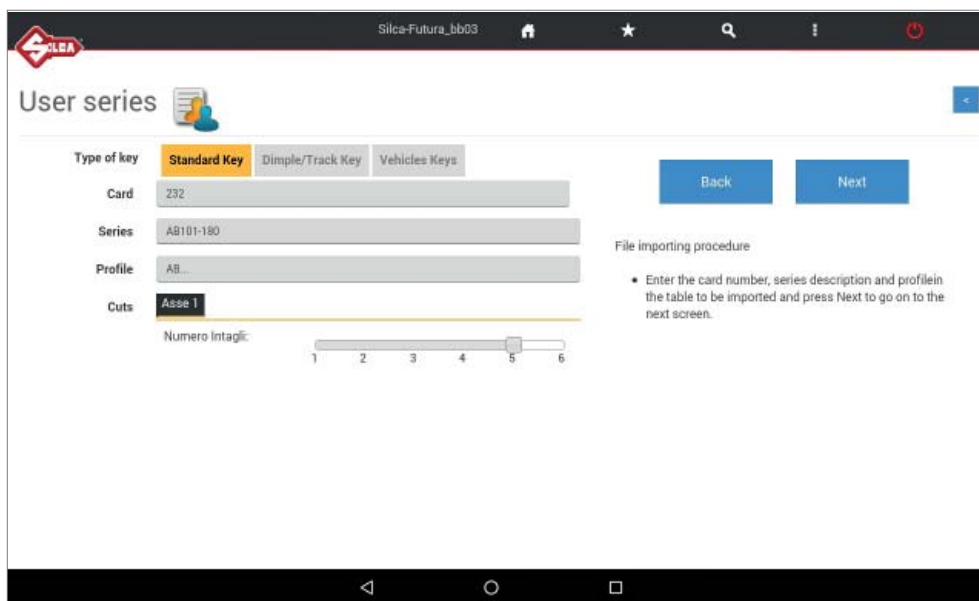

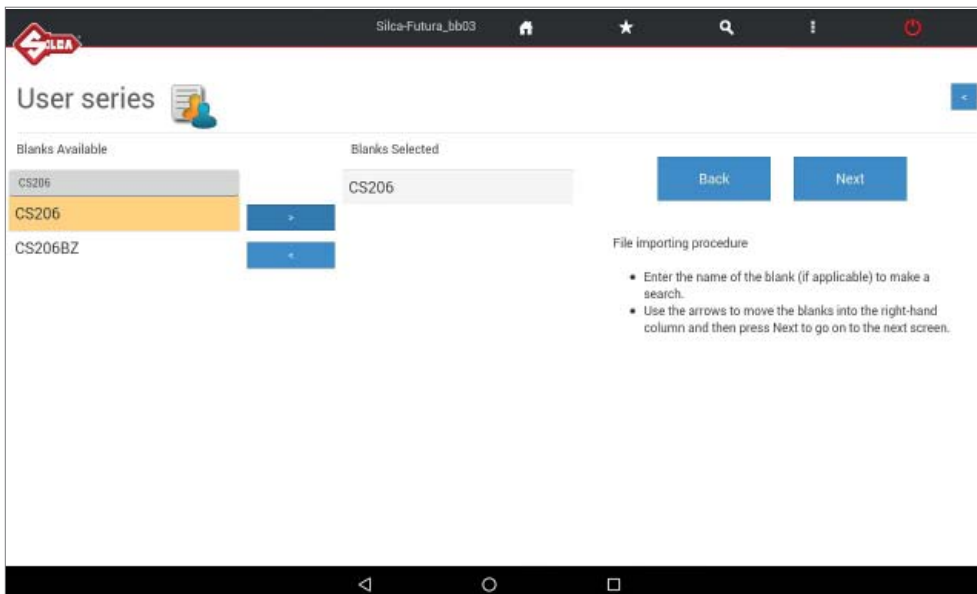
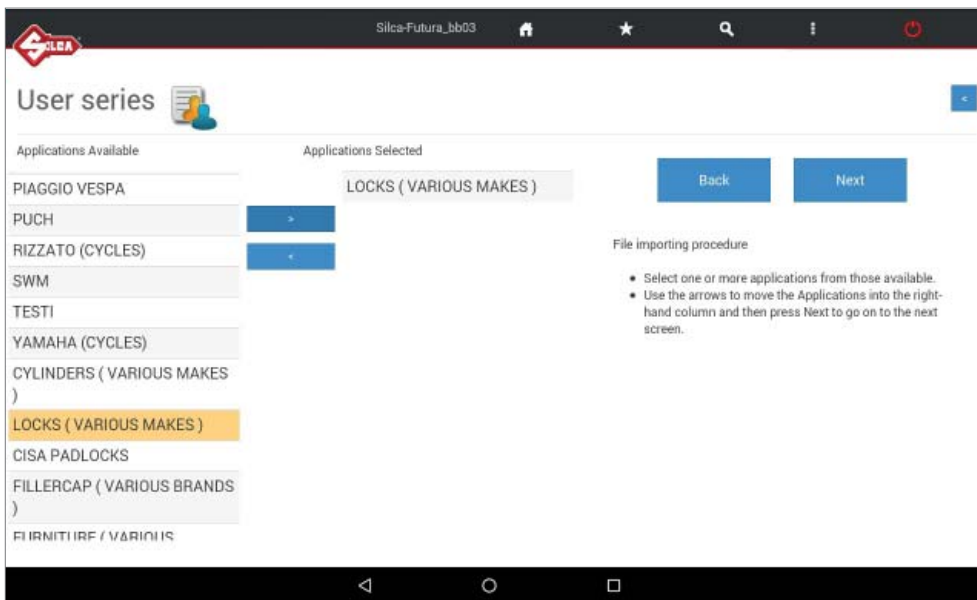
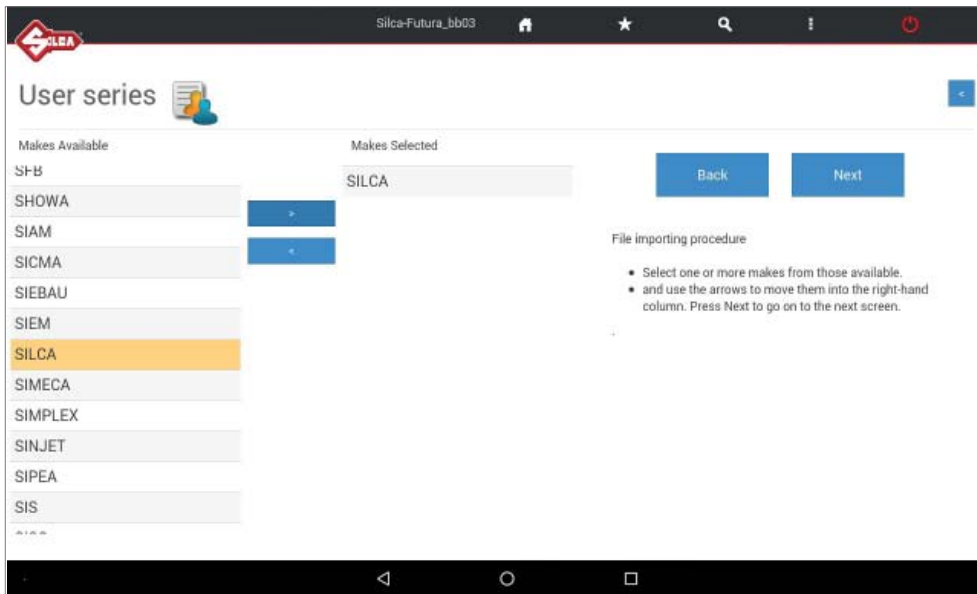

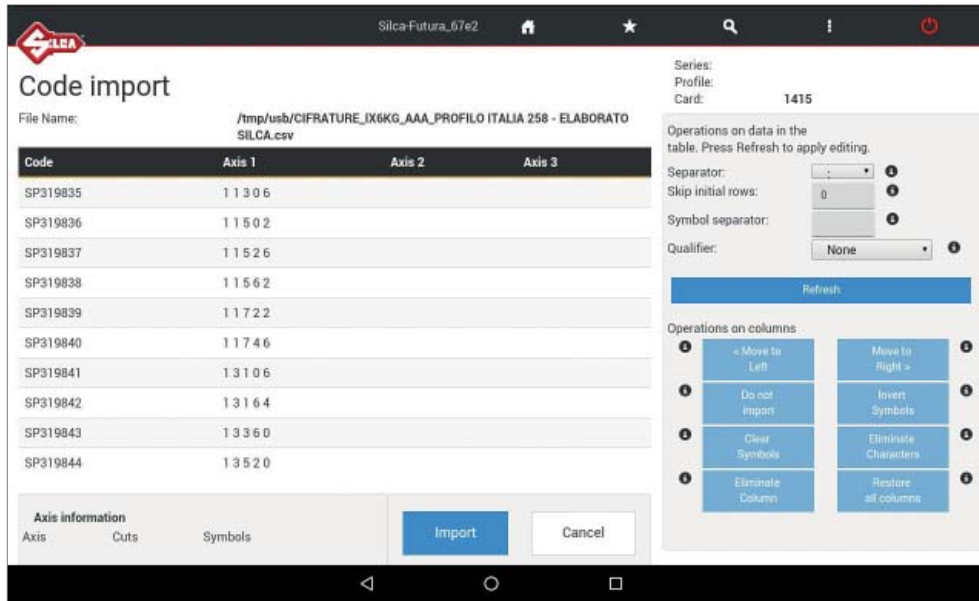

- Tap "Import" to import the file directly without editing.

NOTE: only if necessary, before terminating table import you can edit certain parameters using the menu on the right (Operation on data in the table and/or Operations on columns).

NOTE: Tap  to view information about the field.

- After editing the parameters "Operation on data in the table" tap the "Refresh" key".
- After carrying out operations in the columns, tap the "Import" button to start importing the files.

At the end of the operations the following screen will appear:

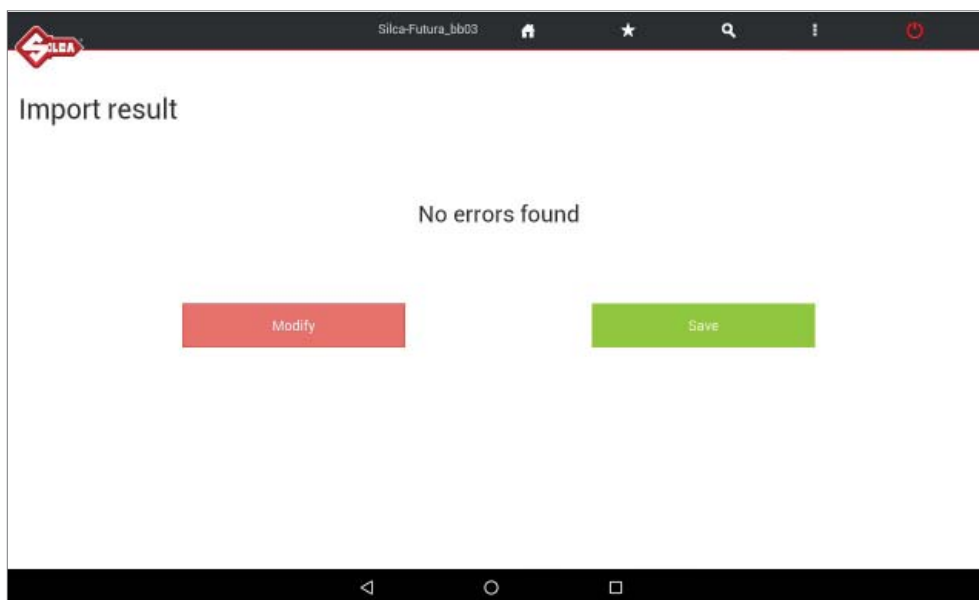

- Tap "Save" to save the new User series.
- Tap "Modify" to make changes.

10 CODE MAKER

This function is not available for Futura One ABUS and Futura Pro One ABUS.

The Code Maker function (option to buy) is used to create a new data card with user-definable cutting parameters.

An explanation of how to use the data card parameters is given in the User Data Card guided creation procedure.

When the data card has been created the program proposes the creation of a User Series which also serves as a link to a personal code table.

Note: new data cards can be created using the accessories, cutters and clamps listed below:

Data cards for DIMPLE keys

Clamp to be used: **01R**

Jaws to be used: **01J-02J 05J-06J**

Cutter to be used: **01D - 02D - 03D - 04D - 05D - 07D - 13DW**

Note: Code Maker may use other accessories in the future.

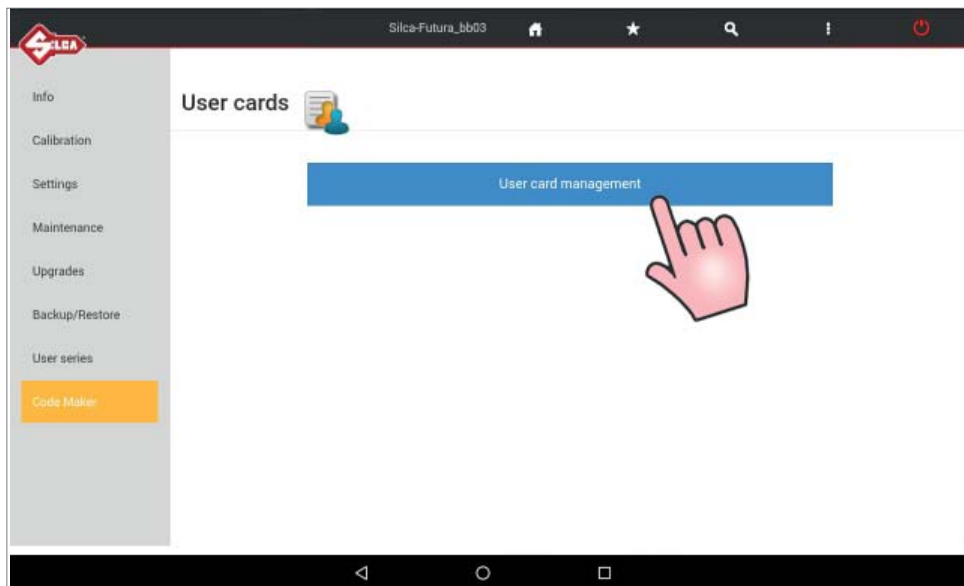

11 TRANSPONDER GUIDE



The Transponder Guide contains all the transponder key copying solutions provided by Silca. Open the **Transponder Guide** MENU - the search window will appear. Enter into the fields the known information about the vehicle or transponder key to view data relating to identification, copying, storage and the procedures provided by Silca:

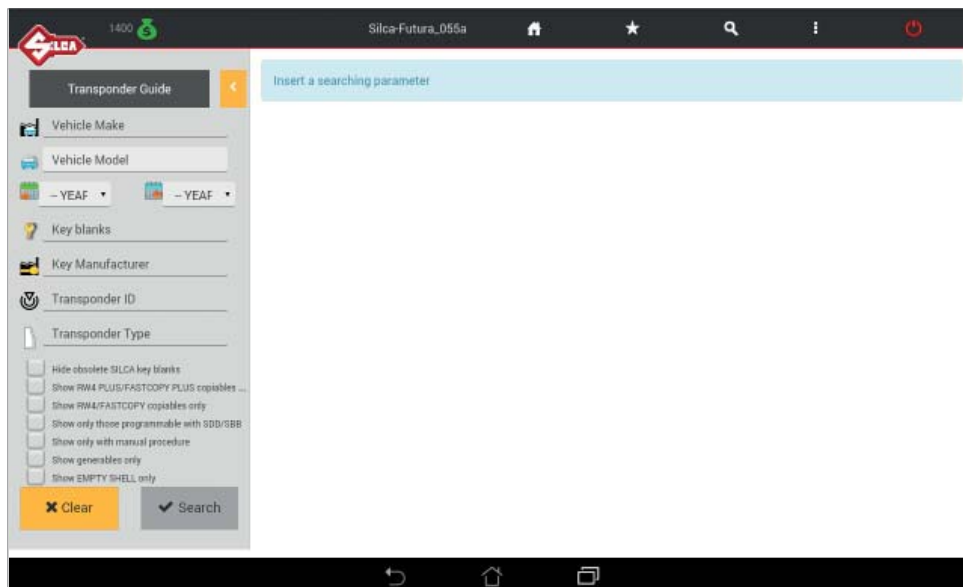

IMPORTANT:

- tap the column icon to learn the meaning of each column
- press the orange arrow to make a new search or go back

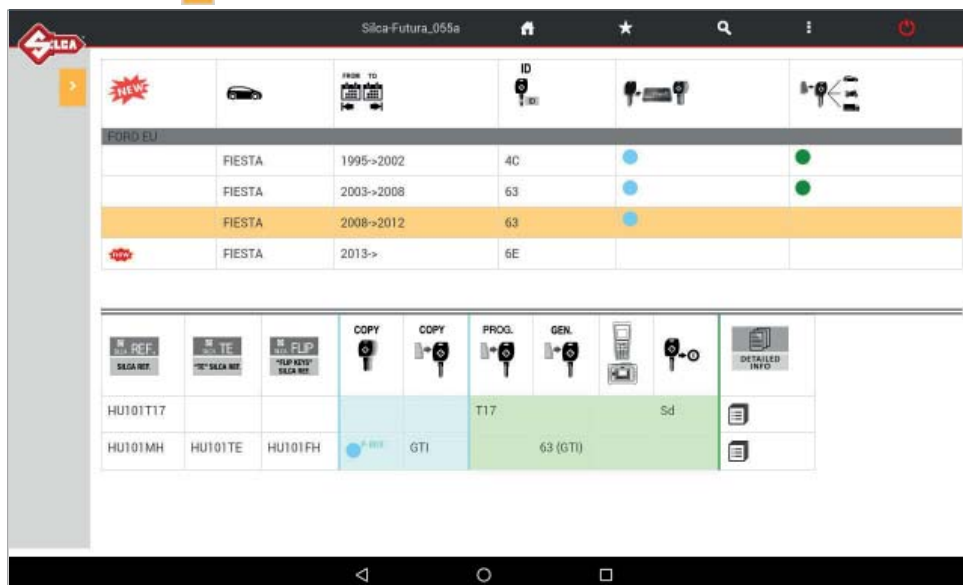

Fig. 31

Select the required car model at the top of the window.

The bottom part of the window will show detailed information about the different possibilities:

(blue section)

- use one of the Silca keys indicated in the first 3 columns to create a clone of the original transponder key, i.e. a key ready for use.

(green section)

- use one of the Silca keys indicated in the first 3 columns to get a key that can be programmed on the vehicle by diagnostics or manual procedure. If there is no solution with Silca keys, when programming by diagnostics or manual procedure, if available, the copy must be made from an original key.



column indicating a Silca key blank complete with transponder or ORIGINAL



column indicating a Silca key blank without transponder



column indicating a Silca FLIP key blank without transponder

Example Fig.15

In this case the user may:

(blue section) => to clone the original key with RW devices

- use HU101MH
- use HU101TE or HU101FH with GTI transponder

(green section) => to programme a key on the vehicle with original diagnostics (sd = see dealer)

- use HU101T17
- use HU101TE or HU101FH with GTI transponder programmed as ID63 or with T17 transponder

Get further details or access “manual programming” procedures by hitting  (see fig.15).

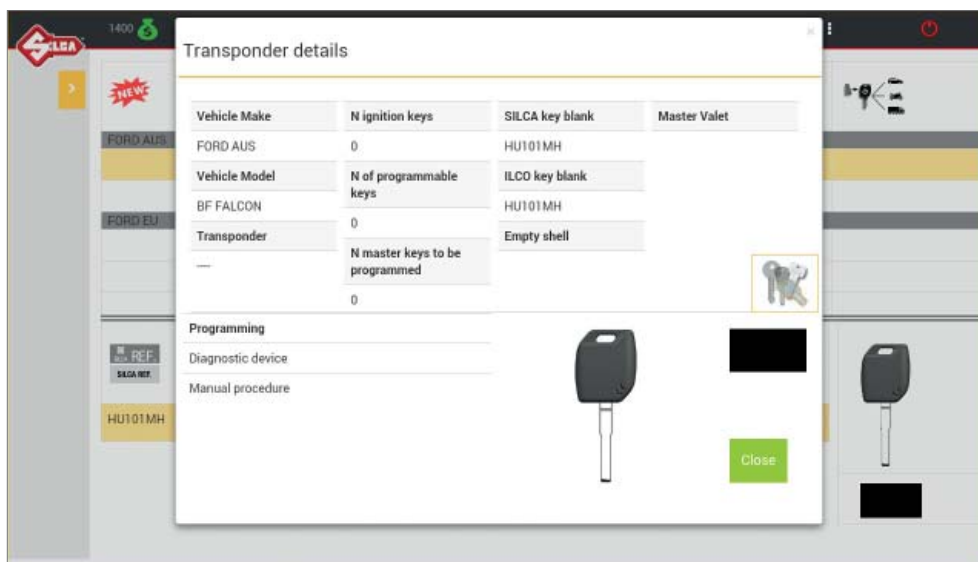



Tap icon  to make a search in the key-cutting section to find the data cards for the Silca key blank selected

12 CHANGING TABLETS

If a new tablet is to replace the previous one, download/install the Futura App. and the customized “Silca Keyboard”.

Proceed as follows:

- 1) Connect the tablet <=> FUTURA in ACCESS POINT mode (see Ch.6.3.3.a).
- 2) Open the browser CHROME  (the CHROME icon is in the Apps page ) and enter the following addresses:
192.168.0.1/Silca.apk to download the App
192.168.0.1/SilcaKeyboard.apk to download the keyboard



- 3) Tap the center bottom “Open all Apps screen” icon 
- 4) Enter “File Manager” and tap on “Downloads”.



Fig. 32

- 5) Tap on the 2 apps just downloaded for installation.

File	Name	Revision date	Size	Category
Download...	Silca.apk	26/04/2018 10:03	2,52 MB	Applications
Docum...	SilcaKeyboard.apk	15/07/2017 12:53	1,12 MB	Applications

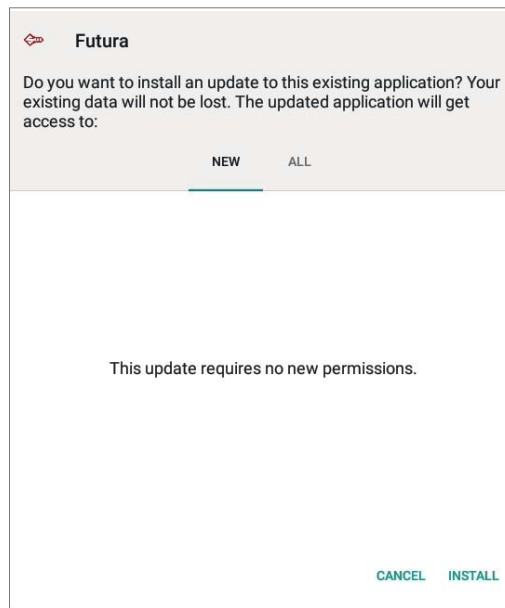

After you install the new Futura application you should move the Silca Futura application icon  to the main screen:

1) Tap the center bottom “Open all Apps screen” icon 

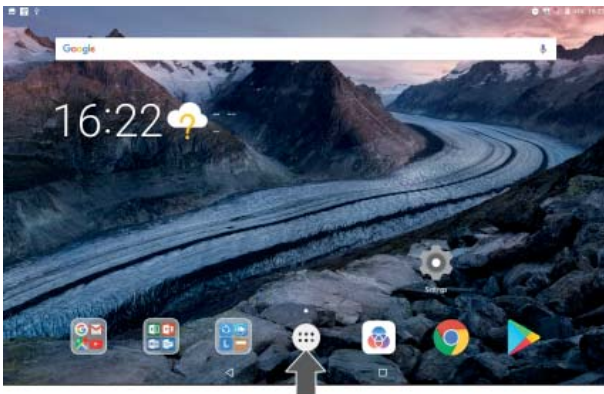

2) Search for “Futura” icon 

3) Tap and hold (keep pressing) the Silca Futura application icon and drag it to the main screen.

13 FUTURA PROCEDURE TO CLEAR CACHE

Clearing the Futura application Cache is recommended to improve the performance of the Futura application.

1) Entering the Android tablet Settings .

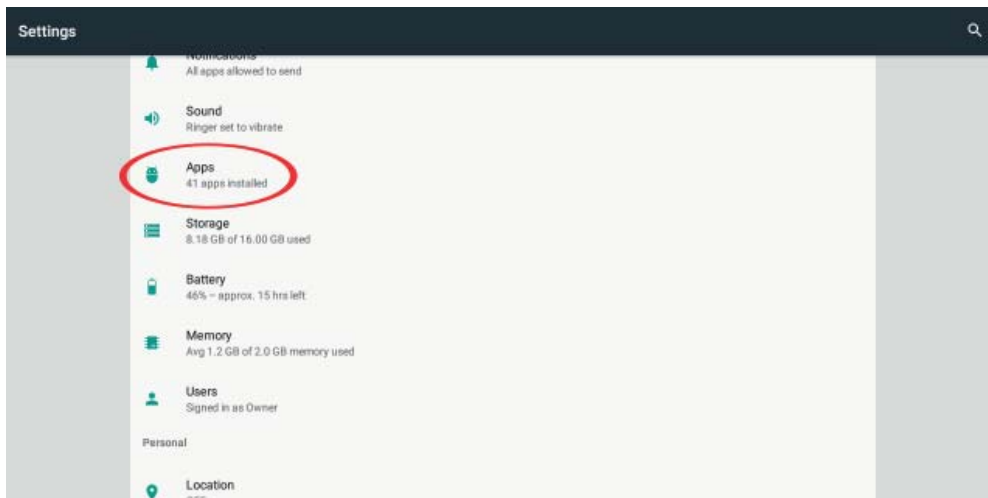

2) Tap on “Apps” and then “Futura”.



3) Enter “Storage” and tap on “CLEAR CACHE”.

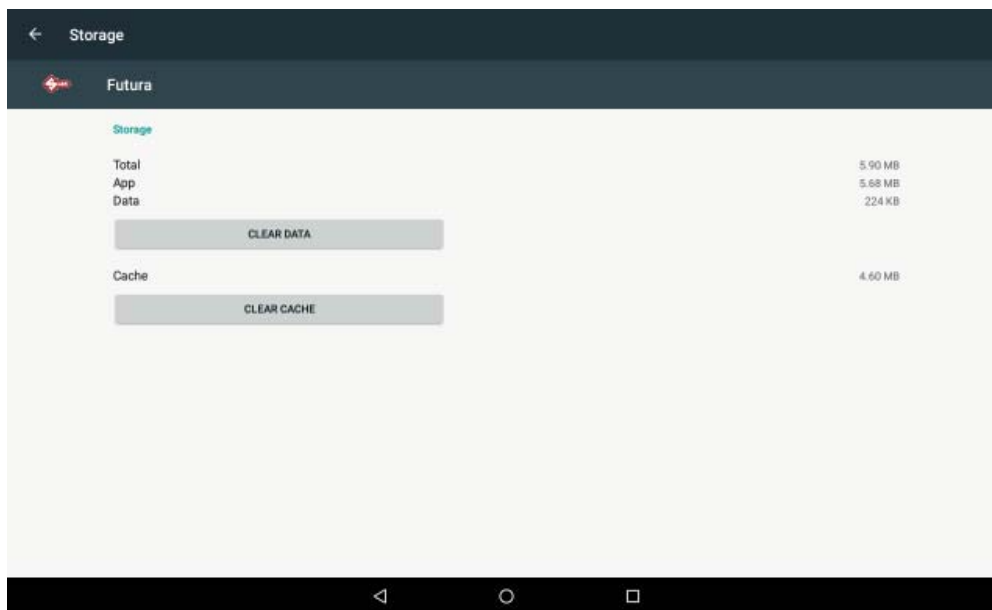

GNU GENERAL PUBLIC LICENSE

This product includes partly software owned by Silca and partly open source software. Below is the original text of the official license for open source software.

On request Silca will provide a DVD with the GPL code included in the FUTURA product.

To make the request contact SILCA at the following address:

SILCA S.p.A.

Via Podgora 20

31020 Vittorio veneto

Italy

Email: service@silca.it

The GPL code used on this product is distributed WITHOUT A WARRANTY and is subject to copyright for one or more writers.

This product also includes software developed by OpenSSL Project for use by the OpenSSL Toolkit.

GNU GENERAL PUBLIC LICENSE Version 2, June 1991

Copyright (C) 1989, 1991 Free Software Foundation, Inc., 51 Franklin Street, Fifth Floor, Boston, MA 02110-1301 USA

Everyone is permitted to copy and distribute verbatim copies of this license document, but changing it is not allowed.

Preamble

The licenses for most software are designed to take away your freedom to share and change it. By contrast, the GNU General Public License is intended to guarantee your freedom to share and change free software--to make sure the software is free for all its users. This General Public License applies to most of the Free Software Foundation's software and to any other program whose authors commit to using it. (Some other Free Software Foundation software is covered by the GNU Lesser General Public License instead.) You can apply it to your programs, too.

When we speak of free software, we are referring to freedom, not price. Our General Public Licenses are designed to make sure that you have the freedom to distribute copies of free software (and charge for this service if you wish), that you receive source code or can get it if you want it, that you can change the software or use pieces of it in new free programs; and that you know you can do these things.

To protect your rights, we need to make restrictions that forbid anyone to deny you these rights or to ask you to surrender the rights. These restrictions translate to certain responsibilities for you if you distribute copies of the software, or if you modify it.

For example, if you distribute copies of such a program, whether gratis or for a fee, you must give the recipients all the rights that you have. You must make sure that they, too, receive or can get the source code. And you must show them these terms so they know their rights.

We protect your rights with two steps: (1) copyright the software, and (2) offer you this license which gives you legal permission to copy, distribute and/or modify the software.

Also, for each author's protection and ours, we want to make certain that everyone understands that there is no warranty for this free software. If the software is modified by someone else and passed on, we want its recipients to know that what they have is not the original, so that any problems introduced by others will not reflect on the original authors' reputations.

Finally, any free program is threatened constantly by software patents. We wish to avoid the danger that redistributors of a free program will individually obtain patent licenses, in effect making the program proprietary. To prevent this, we have made it clear that any patent must be licensed for everyone's free use or not licensed at all.

The precise terms and conditions for copying, distribution and modification follow.

GNU GENERAL PUBLIC LICENSE TERMS AND CONDITIONS FOR COPYING, DISTRIBUTION AND MODIFICATION

0. This License applies to any program or other work which contains a notice placed by the copyright holder saying it may be distributed under the terms of this General Public License. The "Program", below, refers to any such program or work, and a "work based on the Program" means either the Program or any derivative work under copyright law: that is to say, a work containing the Program or a portion of it, either verbatim or with modifications and/or translated into another language. (Hereinafter, translation is included without limitation in the term "modification".) Each licensee is addressed as "you".

Activities other than copying, distribution and modification are not covered by this License; they are outside its scope. The act of running the Program is not restricted, and the output from the Program is covered only if its contents constitute a work based on the Program (independent of having been made by running the Program).

Whether that is true depends on what the Program does.

1. You may copy and distribute verbatim copies of the Program's source code as you receive it, in any medium, provided that you conspicuously and appropriately publish on each copy an appropriate copyright notice and disclaimer of warranty; keep intact all the notices that refer to this License and to the absence of any warranty; and give any other recipients of the Program a copy of this License along with the Program.

You may charge a fee for the physical act of transferring a copy, and you may at your option offer warranty protection in exchange for a fee.

2. You may modify your copy or copies of the Program or any portion of it, thus forming a work based on the Program, and copy and distribute such modifications or work under the terms of Section 1 above, provided that you also meet all of these conditions:

- a) You must cause the modified files to carry prominent notices stating that you changed the files and the date of any change.
- b) You must cause any work that you distribute or publish, that in whole or in part contains or is derived from the Program or any part thereof, to be licensed as a whole at no charge to all third parties under the terms of this License.
- c) If the modified program normally reads commands interactively when run, you must cause it, when started running for such interactive use in the most ordinary way, to print or display an announcement including an appropriate copyright notice and a notice that there is no warranty (or else, saying that you provide a warranty) and that users may redistribute the program under these conditions, and telling the user how to view a copy of this License. (Exception: if the Program itself is interactive but does not normally print such an announcement, your work based on the Program is not required to print an announcement.)

These requirements apply to the modified work as a whole. If identifiable sections of that work are not derived from the Program, and can be reasonably considered independent and separate works in themselves, then this License, and its terms, do not apply to those sections when you distribute them as separate works. But when you distribute the same sections as part of a whole which is a work based on the Program, the distribution of the whole must be on the terms of this License, whose permissions for other licensees extend to the entire whole, and thus to each and every part regardless of who wrote it.

Thus, it is not the intent of this section to claim rights or contest your rights to work written entirely by you; rather, the intent is to exercise the right to control the distribution of derivative or collective works based on the Program.

In addition, mere aggregation of another work not based on the Program with the Program (or with a work based on the Program) on a volume of a storage or distribution medium does not bring the other work under the scope of this License.

3. You may copy and distribute the Program (or a work based on it, under Section 2) in object code or executable form under the terms of Sections 1 and 2 above provided that you also do one of the following:

- a) Accompany it with the complete corresponding machine-readable source code, which must be distributed under the terms of Sections 1 and 2 above on a medium customarily used for software interchange; or,
- b) Accompany it with a written offer, valid for at least three years, to give any third party, for a charge no more than your cost of physically performing source distribution, a complete machine-readable copy of the corresponding source code, to be distributed under the terms of Sections 1 and 2 above on a medium customarily used for software interchange; or,
- c) Accompany it with the information you received as to the offer to distribute corresponding source code. (This alternative is allowed only for noncommercial distribution and only if you received the program in object code or executable form with such an offer, in accord with Subsection b above.)

The source code for a work means the preferred form of the work for making modifications to it. For an executable work, complete source code means all the source code for all modules it contains, plus any associated interface definition files, plus the scripts used to control compilation and installation of the executable. However, as a special exception, the source code distributed need not include anything that is normally distributed (in either source or binary form) with the major components (compiler, kernel, and so on) of the operating system on which the executable runs, unless that component itself accompanies the executable.

If distribution of executable or object code is made by offering access to copy from a designated place, then offering equivalent access to copy the source code from the same place counts as distribution of the source code, even though third parties are not compelled to copy the source along with the object code.

4. You may not copy, modify, sublicense, or distribute the Program except as expressly provided under this License. Any attempt otherwise to copy, modify, sublicense or distribute the Program is void, and will automatically terminate your rights under this License.

However, parties who have received copies, or rights, from you under this License will not have their licenses terminated so long as such parties remain in full compliance.

5. You are not required to accept this License, since you have not signed it. However, nothing else grants you permission to modify or distribute the Program or its derivative works. These actions are prohibited by law if you do not accept this License. Therefore, by modifying or distributing the Program (or any work based on the Program), you indicate your acceptance of this License to do so, and all its terms and conditions for copying, distributing or modifying the Program or works based on it.

6. Each time you redistribute the Program (or any work based on the Program), the recipient automatically receives a license from the original licensor to copy, distribute or modify the Program subject to these terms and conditions. You may not impose any further restrictions on the recipients' exercise of the rights granted herein. You are not responsible for enforcing compliance by third parties to this License.

7. If, as a consequence of a court judgment or allegation of patent infringement or for any other reason (not limited to patent issues), conditions are imposed on you (whether by court order, agreement or otherwise) that contradict the conditions of this License, they do not excuse you from the conditions of this License. If you cannot distribute so as to satisfy simultaneously your obligations under this License and any other pertinent obligations, then as a consequence you may not distribute the Program at all. For example, if a patent license would not permit royalty-free redistribution of the Program by all those who receive copies directly or indirectly through you, then the only way you could satisfy both it and this License would be to refrain entirely from distribution of the Program.

If any portion of this section is held invalid or unenforceable under any particular circumstance, the balance of the section is intended to apply and the section as a whole is intended to apply in other circumstances.

It is not the purpose of this section to induce you to infringe any patents or other property right claims or to contest validity of any such claims; this section has the sole purpose of protecting the integrity of the free software distribution system, which is implemented by public license practices. Many people have made generous contributions to the wide range of software distributed through that system in reliance on consistent application of that system; it is up to the author/donor to decide if he or she is willing to distribute software through any other system and a licensee cannot impose that choice.

This section is intended to make thoroughly clear what is believed to be a consequence of the rest of this License.

8. If the distribution and/or use of the Program is restricted in certain countries either by patents or by copyrighted interfaces, the original copyright holder who places the Program under this License may add an explicit geographical distribution limitation excluding those countries, so that distribution is permitted only in or among countries not thus excluded. In such case, this License incorporates the limitation as if written in the body of this License.

9. The Free Software Foundation may publish revised and/or new versions of the General Public License from time to time. Such new versions will be similar in spirit to the present version, but may differ in detail to address new problems or concerns.

Each version is given a distinguishing version number. If the Program specifies a version number of this License which applies to it and "any later version", you have the option of following the terms and conditions either of that version or of any later version published by the Free Software Foundation. If the Program does not specify a version number of this License, you may choose any version ever published by the Free Software Foundation.

10. If you wish to incorporate parts of the Program into other free programs whose distribution conditions are different, write to the author to ask for permission. For software which is copyrighted by the Free Software Foundation, write to the Free Software Foundation; we sometimes make exceptions for this. Our decision will be guided by the two goals of preserving the free status of all derivatives of our free software and of promoting the sharing and reuse of software generally.

NO WARRANTY

11. BECAUSE THE PROGRAM IS LICENSED FREE OF CHARGE, THERE IS NO WARRANTY FOR THE PROGRAM, TO THE EXTENT PERMITTED BY APPLICABLE LAW. EXCEPT WHEN OTHERWISE STATED IN WRITING THE COPYRIGHT HOLDERS AND/OR OTHER PARTIES PROVIDE THE PROGRAM "AS IS" WITHOUT WARRANTY OF ANY KIND, EITHER EXPRESSED OR IMPLIED, INCLUDING, BUT NOT LIMITED TO, THE IMPLIED WARRANTIES OF MERCHANTABILITY AND FITNESS FOR A PARTICULAR PURPOSE. THE ENTIRE RISK AS TO THE QUALITY AND PERFORMANCE OF THE PROGRAM IS WITH YOU. SHOULD THE PROGRAM PROVE DEFECTIVE, YOU ASSUME THE COST OF ALL NECESSARY SERVICING, REPAIR OR CORRECTION.

12. IN NO EVENT UNLESS REQUIRED BY APPLICABLE LAW OR AGREED TO IN WRITING WILL ANY COPYRIGHT HOLDER, OR ANY OTHER PARTY WHO MAY MODIFY AND/OR REDISTRIBUTE THE PROGRAM AS PERMITTED ABOVE, BE LIABLE TO YOU FOR DAMAGES, INCLUDING ANY GENERAL, SPECIAL, INCIDENTAL OR CONSEQUENTIAL DAMAGES ARISING OUT OF THE USE OR INABILITY TO USE THE PROGRAM (INCLUDING BUT NOT LIMITED TO LOSS OF DATA OR DATA BEING RENDERED INACCURATE OR LOSSES SUSTAINED BY YOU OR THIRD PARTIES OR A FAILURE OF THE PROGRAM TO OPERATE WITH ANY OTHER PROGRAMS), EVEN IF SUCH HOLDER OR OTHER PARTY HAS BEEN ADVISED OF THE POSSIBILITY OF SUCH DAMAGES.

END OF TERMS AND CONDITIONS

How to Apply These Terms to Your New Programs

If you develop a new program, and you want it to be of the greatest possible use to the public, the best way to achieve this is to make it free software which everyone can redistribute and change under these terms.

To do so, attach the following notices to the program. It is safest to attach them to the start of each source file to most effectively convey the exclusion of warranty; and each file should have at least the "copyright" line and a pointer to where the full notice is found.

<one line to give the program's name and a brief idea of what it does.>

Copyright (C) <year> <name of author>

This program is free software; you can redistribute it and/or modify it under the terms of the GNU General Public License as published by the Free Software Foundation; either version 2 of the License, or (at your option) any later version.

This program is distributed in the hope that it will be useful, but WITHOUT ANY WARRANTY; without even the implied warranty of MERCHANTABILITY or FITNESS FOR A PARTICULAR PURPOSE. See the GNU General Public License for more details.

You should have received a copy of the GNU General Public License along with this program; if not, write to the Free Software Foundation, Inc., 51 Franklin Street, Fifth Floor, Boston, MA 02110-1301 USA.

Also add information on how to contact you by electronic and paper mail.

If the program is interactive, make it output a short notice like this when it starts in an interactive mode:

Gnomovision version 69, Copyright (C) year name of author

Gnomovision comes with ABSOLUTELY NO WARRANTY; for details type `show w'. This is free software, and you are welcome to redistribute it under certain conditions; type `show c' for details.

The hypothetical commands `show w' and `show c' should show the appropriate parts of the General Public License. Of course, the commands you use may be called something other than `show w' and `show c'; they could even be mouse-clicks or menu items--whatever suits your program.

You should also get your employer (if you work as a programmer) or your school, if any, to sign a "copyright disclaimer" for the program, if necessary. Here is a sample; alter the names:

Yoyodyne, Inc., hereby disclaims all copyright interest in the program `Gnomovision' (which makes passes at compilers) written by James Hacker.

<signature of Ty Coon>, 1 April 1989 Ty Coon, President of Vice

This General Public License does not permit incorporating your program into proprietary programs. If your program is a subroutine library, you may consider it more useful to permit linking proprietary applications with the library. If this is what you want to do, use the GNU Lesser General Public License instead of this License.